



KKIK - FSRD

Jurnal
Sosioteknologi

Website: <https://journals.itb.ac.id/index.php/sostek/index>



Vocational Interactive Wall Design Based on Human Centered Design with User Experience Questionnaire Measurement

Rancangan Dinding Interaktif Vokasi Berbasis Human Centered Design dengan Pengukuran User Experience Questionnaire

Jeremy Amanda Putra Tarihoran¹, Amirul Mu'minin²

Multimedia Engineering Technology Program, Politeknik Negeri Batam

amirul@polibatam.ac.id

Phone Number/WA: 082290154545

ARTICLE INFO

Keywords:

Interactive Wall, Augmented Reality, Edutainment, Human Centered Design, User Experience Questionnaire

ABSTRACT

Augmented Reality (AR) based Vocational Interactive Wall is a wall that contains content from the Directorate General of Vocational Education or a plain-looking mural using Augmented Reality so that it will be more immersive and enhance the visitor experience, and offer interactive Edutainment that allows visitors to play, learn, and have fun simultaneously. Augmented reality is a technology that creates digital information. Computers make it in real-time by combining digital and original displays. This research aims to facilitate students or visitors who want to know the profile of the Directorate General of Vocational Education. The research method used in this research is the Human Centered Design (HCD) method for product design and User Experience Questionnaire (UEQ) for user experience measurement. The results of the user experience analysis of 20 respondents at Vokasi Fest x Kampus Merdeka 2023 show that the Augmented Reality-based Vocational Interactive Wall application is categorized as "Feasible" to use, based on the benchmark results obtained from a scale of -3 to 3.

INFO ARTIKEL

ABSTRAK

Kata kunci:

Dinding Interaktif, Augmented Reality, Edutainment, Human Centered Design, User Experience Questionnaire

ABSTRAK

Dinding Interaktif Vokasi berbasis Augmented Reality (AR) adalah Dinding yang berisikan konten dari Direktorat Jendral Pendidikan Vokasi atau mural yang tampak polos menggunakan Augmented Reality sehingga akan lebih imersif dan meningkatkan pengalaman pengunjung, serta menawarkan Edutainment interaktif yang memungkinkan pengunjung untuk bermain, belajar, dan bersenang-senang secara simultan. Augmented Reality adalah teknologi yang menciptakan informasi digital yang dibuat oleh komputer secara real-time dengan memadukan tampilan digital dengan tampilan asli. Penelitian ini bertujuan untuk memudahkan pelajar atau pengunjung yang ingin mengetahui profil Direktorat Jendral Pendidikan Vokasi. Metode penelitian yang digunakan dalam penelitian ini adalah Metode Human Centered Design (HCD) untuk perancangan produk dan User Experience Questionnaire (UEQ) untuk pengukuran pengalaman pengguna. Hasil analisis pengalaman pengguna terhadap 20 responden di Vokasi Fest x Kampus Merdeka 2023 memperlihatkan bahwa aplikasi Dinding Interaktif Vokasi berbasis Augmented Reality dikategorikan "Layak" untuk digunakan, berdasarkan hasil benchmark yang didapatkan dari skala -3 sampai 3.

INTRODUCTION

Augmented reality (AR) technology has penetrated various sectors, such as education, healthcare, entertainment, and military. It enables more immersive interactive experiences and is effective as an information medium (Alfitriani et al., 2021). In education, AR facilitates interactive learning by increasing student engagement. In the context of modern technology, interactive media that uses motion graphics or video to convey an interesting message is further enriched by the integration of AR technology. The use of this technology allows users to interact with content more immersively and increases the effectiveness of message delivery in the digital age (Carolina, 2022). Therefore, since AR is an attractive visual medium, it can act as an interactive tool to help students who are less motivated in the learning process (Waliyuddin & Sulisworo, 2022).

Research on the utilization of AR as a promotional media for android-based tourist objects has successfully detected the target image (marker) and brought up 3D animation with tourist objects (Dewi & Ikbal, 2022). From this research, it shows the effective utilization of AR as a promotional media. This technology has also been used in the Vocational Interactive Wall application based on Augmented Reality. This Interactive Wall is made as a 2D moving image information media that displays the Profile of the Directorate General of Vocational Education in Indonesia.

One of the findings of previous research related to Augmented Reality there is the use of the Marker Based Tracking Method with campus building content as an Augmented Reality object in its application. This research aims to facilitate new students who want to find information about the location of the building that serves as the student's lecture (Yosephine et al., 2022). The results of these studies show that the use of augmented reality is an effective information medium. From this study, researchers were inspired by the effectiveness of Android-based Augmented Reality learning media, which is also very effective in providing users with an immersive learning experience (Prayitno et al., 2023).

Based on the existing problems, this research aims to help students or visitors who want to learn more about the Directorate General of Vocational Education in Indonesia, which uses Augmented Reality (AR) technology to create an Android-based application consisting of information from the Directorate General of Vocational Education. The use of a Smartphone with Augmented Reality technology integrated into it makes it possible to take pictures of objects using the device's camera in real-time and without having to search for them online. Based on the description above, the author took the research title "Vocational Interactive Wall Design Based on Human Centered Design with User Experience Questionnaire Measurement".

METHOD

1. Human Centered Design

The Human Centered Design (HCD) method was used in the design of this product. This approach is divided into three phases: ideation, inspiration, and implementation (Kuningan et al., 2021)(Bax, 2018). This method is a user-centered design framework for the system to be created. To understand people or users, the HCD phase starts with understanding people and their needs. Iteration is done using the HCD technique to ensure that users get what they need (Kuningan et al., 2021).

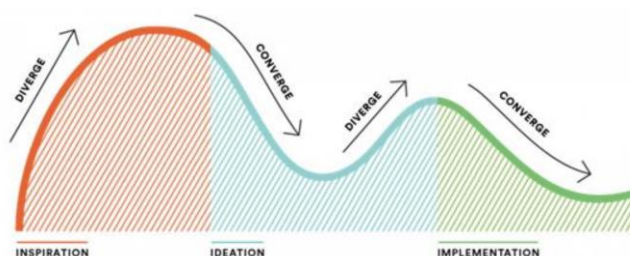

Figure 1 Stages of the HCD method
Source: (Bax, 2018).

The inspiration phase involves the designer in the position that will use the system to understand the problem being faced so that the designer can detect real needs and problems. The ideation phase aims to develop a prototype that will be used and relativize the concepts learned from the previous phase. The implementation phase aims to overcome the problems identified in the previous phase, ideas and findings will be converted into something useful (Kuningan et al., 2021)(Bax, 2018). After a user-centered solution has been developed, the next stage is to assess the efficacy of the solution by determining whether or not it meets the original objectives and making necessary adjustments as it evolves. At this stage, the researcher used the User Experience Questionnaire (UEQ) method to measure the user experience with the interactive product (Putu et al., 2022). UEQ measurements are considered useful because they provide comprehensive user experience measurement results (Rasio Henim & Perdana Sari, 2020). HCD helps the development of products and services that are more user-friendly, efficient, and visually appealing and provide high customer satisfaction for businesses (Shanardi Wijaya, 2019).

2. Population and Sample

Population can be concluded that research can be understood as all elements, including objects and subjects with certain qualities, based on the understanding of several experts (Fadilah Amin et al., 2023). The population in this study were visitors to the exhibition of Vokasi Fest X Kampus Merdeka 2023. Meanwhile, a sample is a portion of the population to describe the overall population (Fadilah Amin et al., 2023). In quantitative research, the minimum recommended sample size is 20 samples because a lot of data needed depends on the level of user agreement participating in the questionnaire (Schrepp, 2023). The data collected for this study were collected within two days of the event, and a total of 20 respondents from visitors to the Vokasi Fest X Kampus Merdeka 2023 event.

3. User Experience Questionnaire

The purpose of the UEQ questionnaire is to measure user experience with interactive products quickly and accurately through user assessment (Putu et al., 2022). UEQ is used in the third phase of HCD for measurement, UEQ can facilitate in getting comprehensive user experience measurement results (Rasio Henim & Perdana Sari, 2020). HCD can also shape UEQ development by providing insight into the needs, goals, and behaviors of target users. Understanding these aspects helps in formulating relevant and meaningful questions for the questionnaire. UEQ, on the other hand, serves as a tool to apply the principles of HCD by capturing user feedback and insights. The data collected from this questionnaire can be used for design iterations, bringing it more in line with user needs and preferences. There are 26 questions in this UEQ questionnaire, which are divided into six assessment categories: Attractiveness (how attractive the product looks overall), Clarity (how easy it is to use), Efficient (whether the user completes the task or process without much difficulty), Precision (whether the user can control how the product interacts with the user), Stimulation (whether the product can inspire the user), and Novelty (how new and innovative the product is).

4. User Experience Measurement Stage with UEQ

User Experience Questionnaire (UEQ) can measure user experience more broadly and thoroughly because it includes an assessment based on six user experience scales. UEQ has three main aspects, namely Attractiveness, Pragmatic Quality, and Hedonic Quality. Attractiveness is a pure value aspect, which is the user's impression of the system's attractiveness. Clarity, Efficiency, and Accuracy are aspects of Pragmatic Quality, which is the ability of a product to support users to achieve goals in the design of products, systems, and services. Furthermore, Stimulation and Novelty are aspects of Hedonic Quality, aimed at fulfilling psychological needs and not having the goal of fulfilling tasks, such as pleasure when using renewable products and designs (Hinderks, 2020)(Kollmorgen et al., 2022).

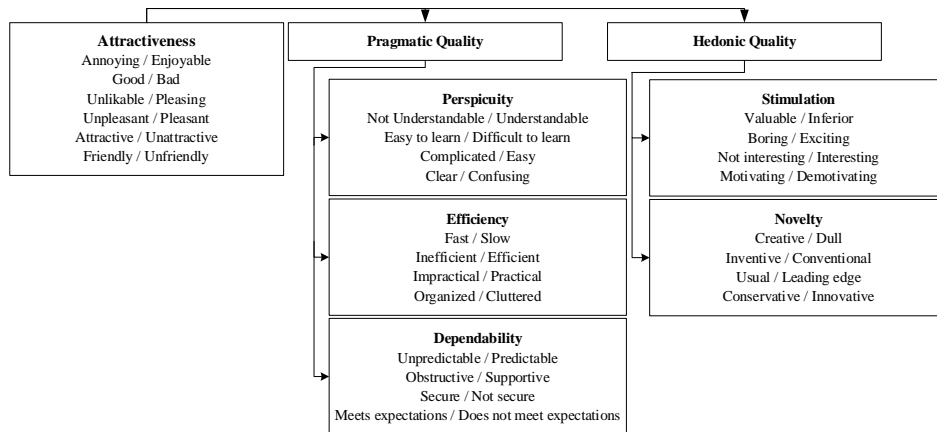

Figure 2 UEQ Scale Structure Assumptions of Pragmatic Quality and Hedonic Quality
Source: (Schrepp, 2023).

The questionnaire contains 26 questions and has a rating from 1-7. Each question in the UEQ has a positive and negative value. Positive questions are found in the data items placed on the right side, namely 1, 2, 6, 7, 8, 11, 13, 14, 15, 16, 20, 22, and 26. Other positive questions are placed on the left side, namely 3, 4, 5, 9, 10, 12, 17, 18, 19, 21, 23, 24, and 25 (Ayu Lestari, n.d.). Negative questions can be seen from the pair of positive items because each question in the UEQ questionnaire has a contradictory meaning. The following is an example of the contents of the UEQ questionnaire. Pairs of significantly different attributes can represent the product form the questionnaire. The gradation between opposing attributes is indicated by the circles between the attributes. By selecting the circle that is most similar to their impression, respondents can indicate that they agree with the attribute. The questionnaire questions can be seen in Table 1.

Table 1 26 Variables as Basic UEQ Questionnaire Questions.

Question variable in the form of Adjectives	1	2	3	4	5	6	7	Question variable in the form of Adjectives	Number
annoying	○	○	○	○	○	○	○	enjoyable	1
not understandable	○	○	○	○	○	○	○	understandable	2
creative	○	○	○	○	○	○	○	dull	3
easy to learn	○	○	○	○	○	○	○	difficult to learn	4
valuable	○	○	○	○	○	○	○	inferior	5
boring	○	○	○	○	○	○	○	exciting	6
not interesting	○	○	○	○	○	○	○	interesting	7
unpredictable	○	○	○	○	○	○	○	predictable	8
fast	○	○	○	○	○	○	○	slow	9
inventive	○	○	○	○	○	○	○	conventional	10
obstructive	○	○	○	○	○	○	○	supportive	11
good	○	○	○	○	○	○	○	bad	12
complicated	○	○	○	○	○	○	○	easy	13
unlikable	○	○	○	○	○	○	○	pleasing	14
usual	○	○	○	○	○	○	○	leading edge	15
unpleasant	○	○	○	○	○	○	○	pleasant	16
secure	○	○	○	○	○	○	○	not secure	17
motivating	○	○	○	○	○	○	○	demotivating	18
meets expectations	○	○	○	○	○	○	○	does not meet expectations	19
inefficient	○	○	○	○	○	○	○	efficient	20
clear	○	○	○	○	○	○	○	confusing	21
impractical	○	○	○	○	○	○	○	practical	22
organized	○	○	○	○	○	○	○	cluttered	23
attractive	○	○	○	○	○	○	○	unattractive	24
friendly	○	○	○	○	○	○	○	unfriendly	25
conservative	○	○	○	○	○	○	○	innovative	26

5. UEQ Formulation

Respondents' answers will be converted to data and added to the "Data" page, but the response values will still be displayed on a scale of one to seven.

Data Conversion						
1	2	3	4	5	6	7
↓	↓	↓	↓	↓	↓	↓
-3	-2	-1	0	1	2	3

Figure 3 Conversion data from UEQ scale 1 to 7 to -3 to 3 (Yehezkiel et al., 2023).

The respondents' responses were converted into weighted values between 1 and 7, resulting in a scale with values between -3 (strongly disagree with negative values) and +3 (strongly agree with positive values) or the other way around.

RESULT AND DISCUSSION

1. Inspiration

The choice to use illustrations created with Adobe Illustrator software in the inspiration section can provide several advantages and support the Human Centered Design (HCD) approach.

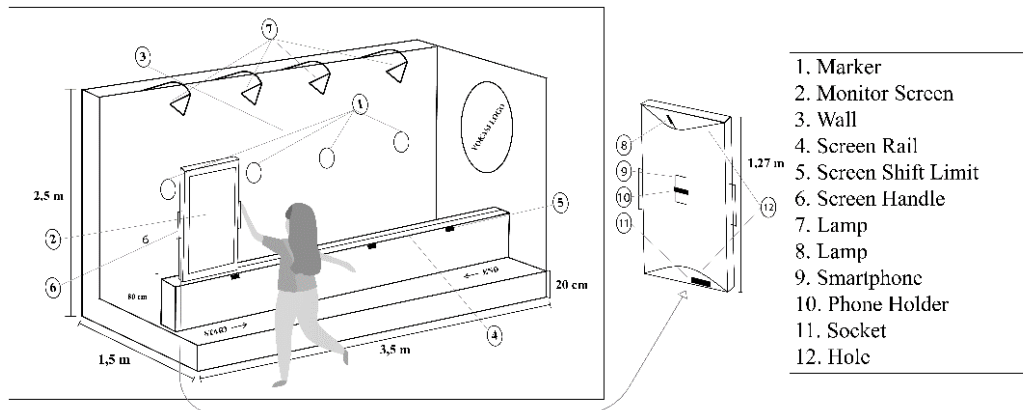

Figure 4 AR-based Vocational Interactive Wall Design based on features.
Source: Personal documentation, 2024

In the picture above, there is a marker as an object that will be detected by the camera before the content is displayed. The monitor screen is a supporting tool for this project because it can display vocational content on a full screen so that users get more experience. Then, the wall is a supporting object for the marker to make it look more immersive. Screen rails support screen movement to make it smoother and more efficient. The screen shift limit is a hint to the user that the screen must be moved until the specified limit mark so that the application can detect images effectively. The screen handle has the same function as the door handle to make it easier for users to shift the screen. Lights as wall and marker lighting. Then, behind the screen, there is a special lamp to help the application detect the marker. Mobile phones are hardware that runs the Augmented Reality-based Vocational Interactive Wall application. A mobile phone holder is a tool that holds the mobile phone and the fan as a mobile phone temperature cooler. The socket is used as a power source for cell phones, screens, and lights. Then, the holes on the top and bottom sides function as airflow to prevent overheating on each device used. The Vocational Interactive Wall can be interacted with using touch and physical shifts that shift the screen from left to right, and the application response is quite fast. The content released is the profile of the Directorate General of Vocational Education, which aims to showcase the Vocational programs that were implemented previously.

2. Ideation

The Activity Diagram in Figure 5 illustrates the process flow of the AR application developed. The marker model used is image tracking. When the camera detects the marker, the application will render the issued object and display the object.

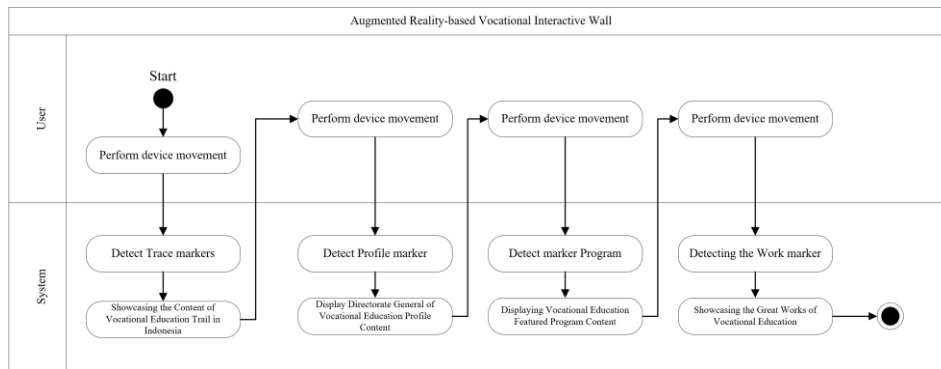

Figure 5 Activity Diagram of AR-based Vocational Interactive Wall
Source: Personal documentation, 2024

AR-based Vocational Interactive Wall product logo.



Figure 6 AR-based Vocational Interactive Wall Application product logo.
Source: Personal documentation, 2024

This logo is made with the Adobe Photoshop application, using Azonix font and a Vocational Interactive Wall image as the background so that users can see that this application is an Augmented Reality-based Vocational Interactive Wall product.



Figure 7 Augmented Reality (AR) based Vocational Interactive Wall Marker created with Adobe Illustrator.
Source: Personal documentation, 2024

Figure 7 shows the result of the Augmented Reality (AR) based Vocational Interactive Wall marker using the Adobe Illustrator application. This image will later be a marker of the Augmented Reality (AR) based Vocational Interactive Wall application.



Figure 8 A. AR content in the form of a Video History of Vocational Education in Indonesia; B. Vocational Education Flagship Program; C. Profile of Directorate General of Vocational Education; D. Innovative Work of Vocational Education in the form of video portrait.
Source: Personal documentation, 2024

Each marker detected by the camera will display the content in Figure 8. The first image discusses the history of Indonesian Vocational Studies from its establishment until now. The second picture displays programs that are the flagship of Vocational Education. The third picture explains the profile of the Directorate General of Vocational Education. The fourth picture displays the innovative works of Vocational Students.

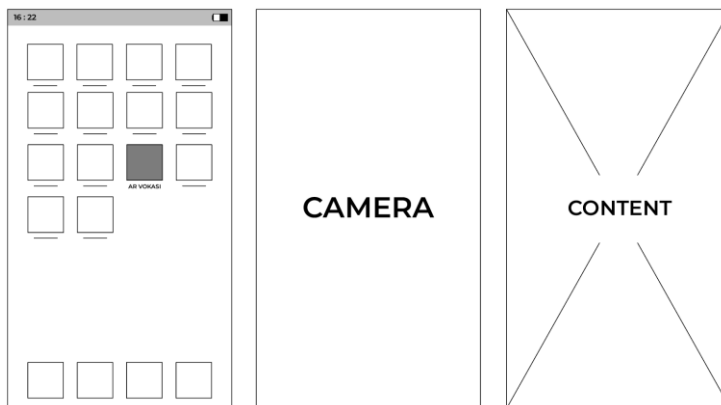

Figure 9 Wireframe of Augmented Reality (AR) based Vocational Interactive Wall Application.
Source: Personal documentation, 2024

In Figure 9, the application only displays the camera when it is opened and will display content in the form of images or videos if the camera detects the marker, as in Figure 7.

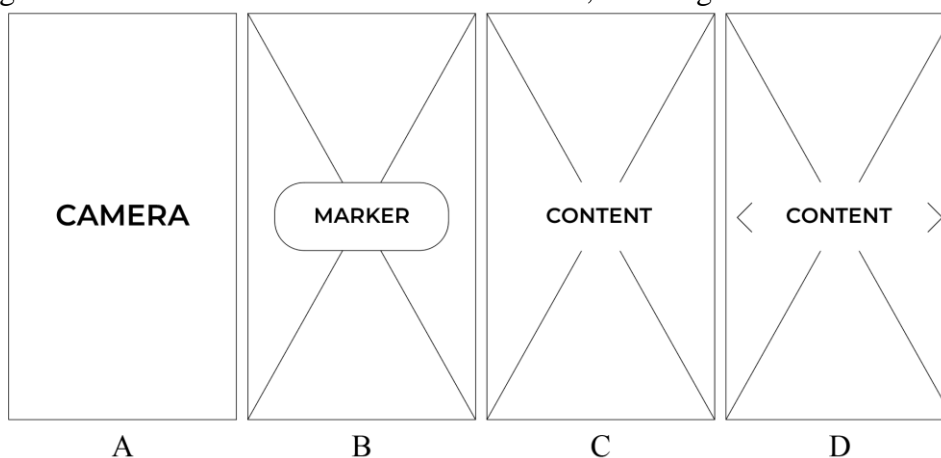

Figure 10 The wireframe of the Augmented Reality (AR) based Vocational Interactive Wall Application was requested by respondents. A. Camera B. Detects Marker; C. Outputs Content; D. There are buttons that can be interacted with.
Source: Personal documentation, 2024

Figure 10 is a wireframe of the application after collecting several respondent requests. Respondents expect the application to display content, respondents or users can interact with the content, for example if the respondent leads to the featured program marker, the respondent can touch the screen and can interact with the content. This method can attract other users if it can be implemented.

3. Implementation

In the implementation stage, the authors conduct continuous iterations, transforming prototypes into final solutions, and pay attention to technical, design, and usage aspects that ensure our product or service meets the needs and expectations of users. One of them is the 3D model of the Interactive Wall, in Figure 11.



Figure 11 3D Modeling of Vocational Interactive Wall based on Augmented Reality.
Source: Personal documentation, 2024

The picture above is a 3D illustration of an augmented reality (AR) based vocational interactive wall, which already resembles its original form.



Figure 12 Product display of Vocational Interactive Wall.
Source: Personal documentation, 2024

Then, after the design is completed, the design components are built in an exhibition so visitors can use them. At that moment, the researcher gathered 20 respondents, whose data is shown in table 2.

Table 2 UEQ Questionnaire results that have been converted to a scale of -3 to 3.

		ITEMS																										
		1	2	3	4	5	6	7	8	9	10	11	12	13	14	15	16	17	18	19	20	21	22	23	24	25	26	
RESPONDEN	1	3	3	3	2	3	-3	3	-1	2	-2	3	3	3	2	1	-1	3	2	2	-2	3	3	3	1	3	-2	
	2	0	1	-2	3	1	0	1	3	3	1	0	1	3	1	2	1	3	-2	2	0	3	3	1	-2	3	1	
	3	3	3	3	3	3	3	3	3	3	3	3	3	3	3	3	2	3	3	3	3	3	3	3	3	3	3	3
	4	2	3	-3	-3	-2	1	2	-2	2	-1	1	1	0	1	1	1	2	1	1	1	0	-1	1	1	2	1	
	5	2	1	2	1	-1	2	2	0	0	2	-1	1	2	2	2	1	2	1	0	-1	0	-2	1	0	1	1	
	6	0	1	0	0	0	0	0	-1	1	1	-1	1	-1	0	-1	0	1	1	1	-1	1	-1	2	1	1	-1	
	7	2	2	-2	-2	-2	3	3	2	-3	-2	3	-3	3	2	1	3	-3	-3	-2	3	-3	2	-3	-3	-3	3	
	8	0	3	0	3	3	3	3	-3	3	-3	3	3	3	3	3	3	3	3	3	3	3	3	3	3	-2	1	0
	9	3	3	1	3	2	3	2	-1	1	1	2	2	3	3	2	2	-1	1	2	2	2	2	2	0	0	1	
	10	1	2	2	2	1	0	2	1	-1	0	1	2	2	2	2	2	2	2	1	3	-2	2	-2	1	0	3	-2
	11	1	1	0	1	1	1	1	0	1	0	1	1	2	1	1	1	2	2	1	2	2	2	3	2	2	3	
	12	2	3	2	3	3	2	2	2	3	-2	2	3	2	3	2	3	3	3	3	3	3	2	2	1	3	3	-3
	13	3	3	3	3	3	3	3	2	2	-2	3	3	1	2	1	2	3	3	2	3	3	2	2	-2	3	2	2

ITEMS																										
	1	2	3	4	5	6	7	8	9	10	11	12	13	14	15	16	17	18	19	20	21	22	23	24	25	26
1	-1	0	0	3	2	1	-1	2	-1	2	1	3	0	2	2	3	2	1	-1	1	1	2	3	2	3	
0	0	0	-1	0	1	1	1	0	-1	0	0	0	0	0	0	0	0	0	0	0	0	0	0	0	1	0
-1	1	0	2	2	0	0	2	0	0	0	0	0	0	0	1	2	1	0	1	1	2	1	0	2	0	
2	3	0	3	2	-2	1	0	3	2	2	3	1	1	3	3	3	1	2	1	2	1	3	3	2	2	
2	2	2	3	3	1	3	3	2	3	2	2	3	2	3	2	3	2	2	3	3	3	3	2	3	3	
2	2	2	2	2	2	2	1	2	-2	2	2	2	2	2	2	2	2	2	2	2	2	2	2	2	2	
2	3	-1	-2	2	0	2	0	2	2	2	2	3	0	2	2	3	3	2	2	3	2	-2	1	2	2	

The results of the respondent data that have been obtained are entered in the "Data" tab. The respondent's score scale shows a rating of 1 to 7. It will then be converted automatically in the "DT" tab with a scale of -3 to 3. Table 3 displays the results of the respondent data.

Table 3 Per-person Scale Average

Respondent	Scale means per person					
	Attractiveness	Perspicuity	Efficiency	Dependability	Stimulation	Novelty
1	1.83	2.75	1.5	1.75	1.25	0
2	0.67	2.5	1.75	2	0	0.5
3	2.83	3	3	3	3	3
4	1.33	0	0.75	0.5	0.5	-0.5
5	1.17	1	-0.5	0.25	1	1.75
6	0.5	0.25	0.25	0	0.25	-0.25
7	-0.33	0	-0.25	0	0.25	0
8	1.33	3	3	1.5	3	0
9	1.67	2.75	1.75	0.5	2	1.25
10	1.67	2	-1	1.75	1	0.5
11	1.33	1.5	2	1	1.25	1
12	2.83	2.5	2.25	2.5	2.5	-0.25
13	1.83	2.5	2.25	2.5	3	1
14	1.5	0.75	1	1.25	2	1
15	0.17	-0.25	0	0.25	0.5	-0.25
16	0.33	1	1	1	0.75	0
17	2.33	2.25	2	1.75	0.5	1.75
18	2.17	2.75	2.75	2.5	2.25	2.75
19	2	2	2	1.75	2	1
20	1.5	1.75	1	1.75	1.75	1.25

Next, calculate the main result of UEQ, which will be the reference for the benchmark calculation. The average and variance of the average results of the resulting data transformation per specified scale are used to build the overall scale and the assumption scale (Attractiveness, Pragmatic Quality, and Hedonicity). The results of the mean, variance, and standard deviation are shown in Table 4 below:

Table 4 Mean, variance, and standard deviation of UEQ Results

Item	Mean	Variance	Std. Dev.	No.	Left	Right	Scale
1	1.5	1.4	1.2	20	annoying	enjoyable	Attractiveness
2	2.0	1.4	1.2	20	not understandable	understandable	Perspicuity
3	0.6	3.1	1.8	20	creative	dull	Novelty
4	1.3	3.9	2.0	20	easy to learn	difficult to learn	Perspicuity
5	1.5	2.8	1.7	20	valuable	inferior	Stimulation
6	1.1	2.8	1.7	20	boring	exciting	Stimulation
7	1.9	1.0	1.0	20	not interesting	interesting	Stimulation
8	0.6	3.0	1.7	20	unpredictable	predictable	Dependability
9	1.4	2.5	1.6	20	fast	slow	Efficiency
10	-0.1	3.4	1.8	20	inventive	conventional	Novelty
11	1.5	1.7	1.3	20	obstructive	supportive	Dependability
12	1.6	2.2	1.5	20	good	bad	Attractiveness
13	1.9	1.7	1.3	20	complicated	easy	Perspicuity
14	1.5	1.2	1.1	20	unlikable	pleasing	Attractiveness
15	1.6	1.2	1.1	20	usual	leading edge	Novelty
16	1.6	1.2	1.1	20	unpleasant	pleasant	Attractiveness
17	2.0	2.6	1.6	20	secure	not secure	Dependability
18	1.4	2.6	1.6	20	motivating	demotivating	Stimulation
19	1.5	1.6	1.3	20	meets expectations	does not meet expectations	Dependability
20	1.1	3.1	1.8	20	inefficient	efficient	Efficiency
21	1.7	2.3	1.5	20	clear	confusing	Perspicuity

Item	Mean	Variance	Std. Dev.	No.	Left	Right	Scale
22	1.4	2.8	1.7	20	impractical	practical	Efficiency
23	1.5	2.7	1.6	20	organized	cluttered	Efficiency
24	0.7	3.4	1.8	20	attractive	unattractive	Attractiveness
25	1.8	2.1	1.4	20	friendly	unfriendly	Attractiveness
26	1.0	3.4	1.8	20	conservative	innovative	Novelty

The typical evaluation value is the standard average value per scale between -0.8 and 0.8; numbers >0.8 indicate a positive evaluation, while values <-0.8 indicate a negative review (Schrepp, 2023). So it can be concluded that the Augmented Reality (AR)-based Vocational Interactive Wall Application has a positive impression of each scale, namely, Attractiveness, Clarity, Efficiency, Accuracy, Stimulation, and Novelty, which can be seen in Table 5.

Table 5 Average Results on 6 UEQ Variables.

UEQ Scales (Mean and Variance)		
Perspicuity	1.700	1.19
Stimulation	1.438	0.98
Attractiveness	1.433	0.71
Dependability	1.375	0.83
Efficiency	1.325	1.36
Novelty	0.775	0.99

Furthermore, the calculation of the results of the three aspects of UEQ seen in Table 7 displays attractiveness, pragmatic quality, and hedonic quality. Attractiveness is a pure valence dimension, Pragmatic Quality is an aspect that describes the quality of user interactions related to tasks or goals, and Hedonic Quality is a description of aspects related to pleasure when using the product. The results obtained by the UEQ evaluation for the attractiveness aspect had a value of 1.43, and for pragmatic quality, they had a value of 1.47. And 1.11 value for Hedonic Quality. This can be seen in Table 6.

Table 6 Average Results of Each Aspect of UEQ.

Pragmatic and Hedonic Quality	
Attractiveness	1.43
Pragmatic Quality	1.47
Hedonic Quality	1.11

The final results of the user experience analysis from the UEQ questionnaire are displayed on the “Benchmark” tab shown in Figure 13.

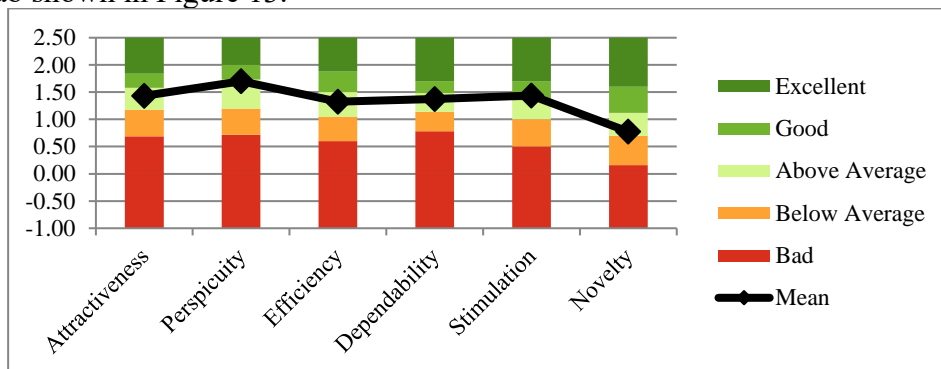

Figure 13 Benchmark Data Set Results.
Source: Personal documentation, 2024

Based on the results of the “Benchmark” tab, it can be seen that for UEQ aspects, namely Attractiveness (1.43), Clarity (1.70), Efficiency (1.33), Accuracy (1.38), Novelty (0.78) are in the good enough category, and Stimulation (1.44) is in the good category.

Discussion

The attractiveness rating scale gets a score above the average of 1.43 (Above Average). Attractiveness shows an assessment that is influenced by a sense of comfort and a sense of fun while playing. Users feel

happy when playing the Augmented Reality (AR) based Vocational Interactive Wall application because it has a good level of attractiveness. Players give opinions about this game as an interactive product because it provides a pleasant user experience, is easy to use, and provides an exhibition experience through Augmented Reality technology.

The Stimulation rating scale shows users feel the direct benefits of the Augmented Reality (AR) based Vocational Interactive Wall application and motivates users who are curious about the profile of the Directorate General of Vocational Education. Provides an interesting and exciting impression because the delivery of information is packaged in an interactive learning model in the form of Augmented Reality-based applications. This scale gets an average score of 1.44 (Good).

The Novelty rating scale shows the level of innovation of the Augmented Reality (AR)-based Vocational Interactive Wall application in application development by getting an average score of 0.78 (Above Average). Users feel that what is available in this application is creative and innovative, and supporting the delivery of information in an interactive learning model by utilizing augmented reality technology will be more effective and provide solutions from monotonous exhibitions.

The Efficiency rating scale shows how quickly users complete the fulfillment of their tasks, such as watching the four contents of the Augmented Reality (AR) based Vocational Interactive Wall application. Users feel that the Augmented Reality (AR) based Vocational Interactive Wall application game is quite practical when played and provides a display that is well organized. The Efficiency scale gets an average value of 1.33 (Above Average).

Accuracy shows an assessment that is influenced by the level of ease of players to predict what to do, provide a sense of security when playing, and the ability to support users to achieve their goals, namely increasing knowledge and successfully watching the four Vocational Education content. The accuracy scale gets an average value of 1.38 (above average), which determines the extent to which interactions in the Augmented Reality (AR) based Vocational Interactive Wall application can be controlled by the user.

Clarity shows an assessment that is influenced by aspects of ease of understanding and learning and the level of complexity that exists in the application. The clarity rating scale gets a value above the average of 1.70 (Above Average). There are obstacles from user experience related to the Clarity rating scale, seen from users feeling that the Augmented Reality (AR) based Vocational Interactive Wall application is still found some displays that are confusing for users such as on the interface display.

CONCLUSION

With the results of the Augmented Reality-based Vocational Interactive Wall design with the Human Centered Design (HCD) method approach, the Interactive Wall prototype design is produced following the wishes and needs of the user. The resulting prototype design has several features, namely: marker, monitor screen, wall, screen rail, screen shift limit, screen handle, lamp, smartphone, smartphone holder, and hole. This Interactive Wall Design will help visitors to the Vokasi Fest x Merdeka Belajar 2023 event who want to know the Directorate General of Vocational Education profile according to user needs.

From the results of research using the User Experience Questionnaire (UEQ), the Augmented Reality (AR) based Vocational Interactive Wall application shows several aspects that affect user experience. Clarity Scale gets an average value of 1.70, Accuracy Scale 1.38, Efficiency Scale 1.33, Stimulation Scale 1.44, Attractiveness Scale 1.43, and Novelty Scale 0.78. The study's conclusion shows that this application provides a pleasant and easy-to-use user experience and an exhibition experience through Augmented Reality technology, with several aspects that affect the user experience, including attractiveness, stimulation, novelty, efficiency, accuracy, and clarity.

However, the novelty part gets a score that is considered sufficient. This is because, during the research, users easily understood how to use the Vocational Interactive Wall, so the Clarity scale got the highest score.

ACKNOWLEDGEMENT

The author would like to thank Batam State Polytechnic and Vocational Education for the tremendous support and cooperation in the smooth creation of the Augmented Reality (AR) based Vocational Interactive Wall and the

procurement of the Vokasi Fest X Kampus Merdeka 2023 Event. I would also like to thank Team Digiars for supporting the research process. In addition, I would like to express my sincere appreciation to Mr. Riwinoto and Nanda Putra Perkasa, who have dedicatedly mentored me and the team. I also want to express my special thanks to Mr. Doni as the exhibition organizer who helped with this project. To my teammate Muhammad Irsyad Khairi, who helped me make the application, the event would not have been as successful as expected without the amazing support and cooperation from all parties.

REFERENCES

- Alfitriani, N., Maula, W. A., & Hadiapurwa, A. (2021). Penggunaan Media Augmented Reality dalam Pembelajaran Mengenal Bentuk Rupa Bumi. In *JPP* (Vol. 38, Issue 1).
- Ayu Lestari, S. (n.d.). Analisis Game Virtual Reality Let's Build a PC Simulator Berbasis User Experience Questionnaire (UEQ). In *Journal of Applied Multimedia and Networking (JAMN): Vols. x, No.x*. <http://jurnal.polibatam.ac.id/index.php/JAMN>
- Bax, N. (2018). *Design Thinking as an approach to engage volunteers in the long-term*. <https://doi.org/10.13140/RG.2.2.25482.52161>
- Carolina, Y. Dela. (2022). Augmented Reality sebagai Media Pembelajaran Interaktif 3D untuk Meningkatkan Motivasi Belajar Siswa Digital Native. *Ideguru: Jurnal Karya Ilmiah Guru*, 8(1), 10–16. <https://doi.org/10.51169/ideguru.v8i1.448>
- Dewi, A. F., & Ikbal, M. (2022). Perancangan Augmented Reality (AR) Sebagai Media Promosi Objek Wisata Berbasis Android. *Infotek : Jurnal Informatika Dan Teknologi*, 5(1), 179–186. <https://doi.org/10.29408/jit.v5i1.4760>
- Fadilah Amin, N., Garancang, S., & Abunawas, K. (2023). *KONSEP UMUM POPULASI DAN SAMPEL DALAM PENELITIAN*.
- Hinderks, A. (2020). *User Experience Questionnaire (UEQ)*. <https://www.ueq-online.org/>
- Kollmorgen, J., Schrepp, M., & Thomaschewski, J. (2022). Impact of Usage Behaviour on the User Experience of Netflix, Microsoft Powerpoint, Bigbluebutton and Zoom. *International Conference on Web Information Systems and Technologies, WEBIST - Proceedings, 2022-October*, 397–406. <https://doi.org/10.5220/0011380100003318>
- Kuningan, K., Setiabudi, K., Jakarta Selatan, K., Khusus Ibukota Jakarta, D., Fadel Khairi, A., & L Mailangkay, A. B. (2021). *SNAP_2021_FULL PAPER_21 PERANCANGAN USER INTERFACE SISTEM INFORMASI CAPAIAN KINERJA DITJEN ILMATE KEMENTERIAN PERINDUSTRIAN DENGAN MENGGUNAKAN METODE HUMAN-CENTERED DESIGN*.
- Prayitno, H., Menrisal, & Astri Indah Juwita. (2023). Efektivitas Aplikasi Media Pembelajaran Berbasis Augmented Reality pada Mata Pelajaran Geografi. *DIAJAR: Jurnal Pendidikan Dan Pembelajaran*, 2(2), 259–266. <https://doi.org/10.54259/diajar.v2i2.1528>
- Putu, L., Citra, D., Wardana, Y., Hadi Wijoyo, S., & Prakoso, B. S. (2022). *Perancangan User Experience dengan menggunakan Metode HCD dan UEQ (Studi Kasus: Layanan Peminjaman Asset Biro Umum dan Protokol Setda Provinsi Bali)* (Vol. 6, Issue 1). <http://j-ptiik.ub.ac.id>
- Rasio Henim, S., & Perdana Sari, R. (2020). Jurnal Politeknik Caltex Riau Evaluasi User Experience Sistem Informasi Akademik Mahasiswa pada Perguruan Tinggi Menggunakan User Experience Questionnaire. In *Jurnal Komputer Terapan* (Vol. 6, Issue 1). <https://jurnal.pcr.ac.id/index.php/jkt/>
- Schrepp, Dr. M. (2023). *User Experience Questionnaire Handbook*. www.ueq-online.org
- Shanardi Wijaya, A. (2019). *Human Centered Design dan Perbedaan dengan User Centered Design – School of Information Systems*. <https://sis.binus.ac.id/2019/06/21/human-centered-design-dan-perbedaan-dengan-user-centered-design-2/>
- Waliyuddin, D. S., & Sulisworo, D. (2022). High Order Thinking Skills and Digital Literacy Skills Instrument Test. *Ideguru: Jurnal Karya Ilmiah Guru*, 7(1). <https://doi.org/10.51169/ideguru.v7i1.310>
- Yehezkiel, S., Marpaung, R., & Nuraeni, N. (2023). Evaluasi User Experience Website E-Learning My-Elnusa Menggunakan User Experience Questionnaire (UEQ). *JURNAL SWABUMI*, 11(1), 2023.
- Yosephine, S., Natalia, Y., Andrijasa, M. F., & Malani, R. (2022). IMPLEMENTASI AUGMENTED REALITY PADA GEDUNG POLITEKNIK NEGERI SAMARINDA MENGGUNAKAN METODE MARKER BASED TRACKING. In *JOURNAL OF INFORMATICS AND COMPUTING (RANDOM)* (Vol. 01, Issue 01).