

**DETEKSI REVIEW SPAM PADA REVIEW
PRODUK AMAZON.COM DENGAN METODE
DETEKSI DUPLIKAT**

TUGAS AKHIR

Oleh :

Madrin Pembun Anadli Arfilida 3311201031

Disusun untuk memenuhi syarat kelulusan program Diploma III



**PROGRAM STUDI TEKNIK INFORMATIKA
POLITEKNIK NEGERI BATAM
BATAM
2015**

HALAMAN PENGESAHAN

**DETEKSI REVIEW SPAM PADA REVIEW PRODUK AMAZON.COM
DENGAN METODE DETEKSI DUPLIKAT**

Oleh :

Madrin Pembun Anadli Arfilida 3311201031

Tugas Akhir ini telah diterima dan disahkan
sebagai persyaratan untuk memperoleh gelar

Ahli Madya

di

**PROGRAM STUDI DIPLOMA 3 TEKNIK INFORMATIKA
POLITEKNIK NEGERI BATAM**

Batam, 11 Agustus 2015

Disetujui oleh;

Pembimbing,

Hilda Widyastuti, M.T

NIK. 197705122012122001

HALAMAN PERNYATAAN

Dengan ini, saya:

NIM : 3311201031

Nama : Madrin Pembun Anadli Arfilida

adalah mahasiswa Teknik Informatika Politeknik Batam yang menyatakan bahwa tugas akhir dengan judul:

DETEKSI REVIEW SPAM PADA REVIEW PRODUK AMAZON.COM DENGAN METODE DETEKSI DUPLIKAT

disusun dengan:

1. tidak melakukan plagiat terhadap naskah karya orang lain
2. tidak melakukan pemalsuan data
3. tidak menggunakan karya orang lain tanpa menyebut sumber asli atau tanpa ijin pemilik

Jika kemudian terbukti terjadi pelanggaran terhadap pernyataan di atas, maka saya bersedia menerima sanksi apapun termasuk pencabutan gelar akademik.

Lembar pernyataan ini juga memberikan hak kepada Politeknik Batam untuk mempergunakan, mendistribusikan ataupun memproduksi ulang seluruh hasil Tugas Akhir ini.

Batam, 11 Agustus 2015

Madrin Pembun Anadli Arfilida
NIM 3311201031

KATA PENGANTAR

Alhamdulillahirrabbi'alamin. Segala puji bagi Allah shalawat dan salam semoga selalu tercurah kepada Rasulullah Muhammad saw,. beserta keluarga, sahabat, dan orang-orang yang mengikuti beliau hingga hari akhir.

Penulis bersyukur dapat menyelesaikan Tugas Akhir ini yang disusun untuk memenuhi syarat kelulusan Program Diploma III Program Studi Teknik Informatika di Politeknik Negeri Batam. Dalam penyusunan Tugas Akhir ini, penulis banyak mendapatkan berbagai dukungan dari berbagai pihak. Oleh karena itu pada kesempatan ini penulis hendak menyampaikan ucapan terimakasih yang sebesar-besarnya kepada :

1. Kedua orang tua kandung, Ibunda Rini Arifin dan Ayahanda Syuherman yang selalu memberikan kasih sayang, dukungan, semangat, moril, materil yang tak terhingga dan doa yang tak henti dipanjatkan untuk penulis.
2. Bapak Gufran Saimima dan Ibu Mariati sebagai orang tua saya juga yang telah memberikan banyak dukungan, bantuan baik langsung maupun tidak langsung kepada penulis.
3. Adik penulis, Madrin Khalil Gibran, yang juga menjadi sumber semangat bagi penulis.
4. Ibu Hilda Widyastuti, MT., selaku pembimbing I, yang telah membimbing penulis, memberikan masukan, koreksi, nasihat dan dukungannya kepada penulis dengan baik dan sangat ramah serta sebagai ketua dalam penelitian lain bersama penulis yang masih terkait dengan Tugas Akhir Penulis, yang membuka wawasan penulis lebih luas.
5. Ibu Sartikha, S.ST., selaku pembimbing II, yang telah membimbing penulis, memberikan masukan, koreksi, nasihat dan dukungannya kepada penulis dengan baik dan sangat ramah serta semangat untuk menyelesaikan tugas akhir ini.

6. Bapak Ari Wibowo, ST. MT, sebagai anggota tim penelitian juga bersama bu Hilda dan penulis, yang telah memacu, membuka wawasan, dan menyemangati penulis untuk menyelesaikan tugas akhir.
7. Bapak Dwi Ely Kurniawan, selaku Pengampu Tugas Akhir, beliau telah memberikan bimbingan, kemudahan, serta *sharing* mengenai tugas akhir.
8. Ibu Nur Zahradi Janah, selaku wali akademik penulis, banyak memberi nasehat, motivasi, dan dukungan lainnya kepada penulis.
9. Kak Festy Winda Sari, Pak Ahmad Hamim Thohari, yang juga telah memberikan banyak dukungan dan bantuan kepada penulis.
10. Julian MC Auley, dari Stanford University yang telah bersedia memberikan data *review* amazon.com untuk penelitian dalam tugas akhir ini.
11. Seluruh pihak yang telah membantu penulis dalam penyelesaian tugas akhir ini yang tidak dapat penulis sebutkan satu-persatu.

Semoga segala kebaikan yang mereka berikan dibalas oleh Allah dengan kebaikan yang banyak.

Penulis menyadari bahwa dalam penyusunan tugas akhir ini tentunya masih banyak kesalahan dan kekurangan. Oleh karena itu kritik dan saran yang membangun sangat penulis harapkan untuk perbaikan di masa yang akan datang. Akhir kata penulis berharap semoga tugas akhir ini dapat bermanfaat khususnya bagi penulis dan umumnya untuk para pembaca.

Batam, 11 Agustus 2015

Penulis

ABSTRAK

DETEKSI REVIEW SPAM PADA REVIEW PRODUK AMAZON.COM DENGAN METODE DETEKSI DUPLIKAT

Maraknya perkembangan teknologi web diberbagai situs dan media sosial membuat orang bebas berekspresi menulis opini dan *review* di dalamnya. Sudah menjadi praktik umum bagi orang-orang untuk melihat opini atau *review* publik sebelum memutuskan membeli suatu barang atau jasa pada situs web komersil salah satunya seperti barang dan jasa di amazon.com, namun tidak ada kontrol kualitas atas suatu opini atau *review* karena kebebasan tersebut. Terkait dapat dipercaya atau tidaknya suatu opini atau *review* tersebut, *review* yang tidak dapat dipercaya merupakan spam. Salah satu bentuk spam yang yaitu *review* spam duplikat.

Aplikasi deteksi *review spam* ini mendeteksi *review* spam duplikat berdasarkan penelitian mengenai *review* spam duplikat pada amazon.com. untuk membantu pembentukkan model untuk deteksi spam lebih lanjut menggunakan fitur-fitur yang ada pada *review*. Deteksi spam tersebut dilakukan juga untuk menghindari tindak ‘menyesatkan’ akan *review* yang tidak dapat dipercaya pada pembaca dan sistem penggalian opini otomatis.

Kata Kunci : Deteksi opini spam, spam *review*, *duplicate review*, *opinion* spam *detection*.

ABSTRACT

REVIEW SPAM DETECTION ON AMAZON.COM'S REVIEW PRODUCT USING DUPLICATE DETECTION METHOD

The rise of web development technologies in various websites and social media make people free to express or write opinions and reviews there. It has become a common practice for people to see opinions or public review before deciding to buy a product or service on a commercial websites such as on amazon.com goods and services, but there is no quality control on an opinion or a review because that freedoms. Related trustworthy or not an opinion or a review, the review can not be trusted to be spam. One form of spam is duplicate spam review.

This review spam detection application detects spam duplicate review by a review of research on spam duplicates on amazon.com. to help establish a model for further spam detection using the features available on the review. The spam detection is also done to avoid acts of 'misleading' will review that can not be trusted by reader and automatic opinion mining system.

Keyword : Deteksi opini spam, spam *review*, *duplicate review*, *opinion spam detection*

DAFTAR ISI

HALAMAN PENGESAHAN	ii
HALAMAN PERNYATAAN	iii
KATA PENGANTAR	iv
ABSTRAK	vi
ABSTRACT	vii
DAFTAR ISI	1
DAFTAR GAMBAR	5
DAFTAR TABEL	7
BAB I PENDAHULUAN	8
1.1 Latar Belakang	8
1.2 Rumusan Masalah	10
1.3 Batasan Masalah	10
1.4 Tujuan Penelitian	10
1.5 Sistematika Penulisan	11
BAB II LANDASAN TEORI	12
2.1 Opini	12
2.2 Opini/Review Spam	12
2.3 Tipe Data yang Digunakan untuk Deteksi Review Spam	13
2.4 Deteksi Review Spam Tipe 1	14
2.5 Deteksi Duplikat dan mendekati Duplikat	15
2.6 Dataset Review Produk Amazon	16
2.6.1 Sumber Dataset	16
2.6.2 Berkas Dataset	16
BAB III ANALISIS DAN PERANCANGAN	18
3.1 Deskripsi Umum Sistem	18
3.2 Karakteristik Pengguna Aplikasi	18
3.3 Kebutuhan Fungsional	19
3.4 Non-Fungsional	19

3.5 Batasan Sistem	19
3.6 Arsitektur Deteksi <i>Review</i> Spam Tipe 1	20
3.6.1 Penyiapan <i>Review</i>	20
3.6.2 Penghapusan <i>Stop-word</i>	23
3.6.3 Deteksi duplikat dan mendekati duplikat.....	25
3.6.4 Verifikasi Kandidat Spam.....	26
3.7 Use Case Diagram.....	29
3.8 Skenario Use Case	29
3.8.1 Skenario Use Case Memasukkan Data <i>Review</i>	29
3.8.2 Skenario Use Case Melihat Daftar <i>Review</i>	30
3.8.3 Skenario Use Case Mengaktifkan Deteksi Duplikasi Pasangan <i>Review</i>	30
3.8.4 Skenario Use Case Melihat Kandidat <i>Review</i> Spam	30
3.8.5 Skenario Use Case Mengaktifkan Verifikasi Kandidat Spam.....	31
3.8.6 Skenario Use Case Melihat <i>Review</i> Spam Terverifikasi.....	31
3.9 Sequence Diagram	32
3.9.1 Sequence Diagram Use Case Memasukkan Dataset <i>Review</i>	32
3.9.2 Sequence Diagram Use Case Melihat Daftar <i>Review</i>	33
3.9.3 Sequence Diagram Use Case Mengaktifkan Deteksi Duplikasi Pasangan <i>Review</i>	33

3.9.4	Sequence Diagram Melihat Kandidat Pasangan <i>Review Spam</i>	34
3.9.5	Sequence Diagram Skenario Use Case Mengaktifkan Verifikasi Kandidat Spam	34
3.9.6	Sequence Melihat <i>Review Spam</i> Terverifikasi.....	35
3.10	Class Diagram	36
3.11	Perancangan Basis Data	37
3.11.1	Entity Relationship Diagram.....	37
3.11.2	Desain Basis Data	37
3.12	Perancangan Antarmuka	38
3.12.1	Antarmuka <i>Homepage</i>	38
3.12.2	Antarmuka <i>Add Review</i>	39
3.12.3	Antarmuka <i>See Review List</i>	40
3.12.4	Antarmuka <i>Start Duplicate Detection</i>	41
3.12.5	Antarmuka <i>See Spam Candidate</i>	41
3.12.6	Antarmuka <i>Verify Spam Candidate</i>	42
3.12.7	Antarmuka <i>See Spam Review List (Verified)</i>	43
BAB IV HASIL DAN PEMBAHASAN		44
4.1	Implementasi	44
4.1.1	Implementasi Kelas	44
4.1.2	Implementasi Antarmuka.....	45
4.1.3	Implementasi <i>Source Code</i>	53
4.1.4	Implementasi Proses	60

4.2	Pengujian.....	62
4.2.1	Tujuan Pengujian	62
4.2.2	Strategi Pengujian	62
4.2.3	Hasil Pengujian	62
4.2.4	Review Spam Duplikat yang Terdeteksi.....	65
BAB V KESIMPULAN DAN SARAN		68
5.1	Kesimpulan	68
5.2	Saran	68
DAFTAR PUSTAKA		69
LAMPIRAN.....		70
	Sampel Data Review Produk Amazon.com.....	70
	Daftar Stop-word	98

DAFTAR GAMBAR

Gambar 1	<i>Deskripsi Umum Sistem Aplikasi</i>	18
Gambar 2	<i>Arsitektur Deteksi Review Spam Tipe 1</i>	20
Gambar 3	<i>Use Case Deteksi Review Spam pada Review Produk</i>	29
Gambar 4	<i>Sequence Diagram Use Case Memasukkan Dataset Review</i>	32
Gambar 5	<i>Sequence Diagram Use Case Melihat Daftar Review</i>	33
Gambar 6	<i>Sequence Diagram Use Case Mengaktifkan Deteksi Duplikasi Pasangan Review</i>	33
Gambar 7	<i>Sequence Diagram Melihat Kandidat Pasangan Review Spam</i>	34
Gambar 8	<i>Sequence Diagram Use Case Mengaktifkan Verifikasi Kandidat Spam</i>	34
Gambar 9	<i>Sequence Diagram Melihat Review Spam Terverifikasi</i>	35
Gambar 10	<i>Class Diagram Deteksi Review Spam</i>	36
Gambar 11	<i>Entity Diagram Relationship Deteksi Review Spam pada Review Produk</i>	37
Gambar 12	<i>Desain Basis Data Deteksi Review Spam pada Review Produk</i>	37
Gambar 13	<i>Rancangan Antarmuka Homepage</i>	38
Gambar 14	<i>Rancangan Antarmuka Add Review</i>	39
Gambar 15	<i>Rancangan Antarmuka See Review List</i>	40
Gambar 16	<i>Rancangan Antarmuka Start Duplicate Detection</i>	41
Gambar 17	<i>Rancangan Antarmuka See Spam Candidate</i>	41
Gambar 18	<i>Rancangan Antarmuka See Review List</i>	42
Gambar 19	<i>Rancangan Antarmuka See Spam Review List</i>	43
Gambar 20	<i>Implementasi Antarmuka Homepage</i>	45
Gambar 21	<i>Implementasi Antarmuka Add Review</i>	46
Gambar 22	<i>Antarmuka tambahan Insert Review Dataset</i>	48
Gambar 23	<i>Implementasi Antarmuka See Review List</i>	49
Gambar 24	<i>Implementasi Antarmuka Start Duplicate Detection</i>	50
Gambar 25	<i>Implementasi Antarmuka See Spam Candidate</i>	51

Gambar 26 <i>Implementasi Antarmuka Verify Spam Candidate</i>	52
Gambar 27 <i>Implementasi Antarmuka See Review List (Verified)</i>	53

DAFTAR TABEL

Tabel 1	<i>Batasan Sistem Hardware, Software, dan Perangkat Pengembang</i>	19
Tabel 2	<i>Metadata Review (contoh)</i>	27
Tabel 3	<i>Perbandingan Kesamaan nilai metadata pasangan review</i>	27
Tabel 4	<i>Algoritma Verifikasi Kandidat Spam</i>	28
Tabel 5	<i>Deskripsi Rancangan Antarmuka Homepage</i>	38
Tabel 6	<i>Deskripsi Rancangan Antarmuka Add Review</i>	39
Tabel 7	<i>Deskripsi Rancangan Antarmuka See Review List</i>	40
Tabel 8	<i>Deskripsi Rancangan Antarmuka Duplicate Detection</i>	41
Tabel 9	<i>Deskripsi Rancangan Antarmuka See Spam Candidate</i>	42
Tabel 10	<i>Deskripsi Rancangan Antarmuka Verify Spam Candidate</i>	42
Tabel 11	<i>Deskripsi Rancangan Antarmuka See Spam Review List</i>	43
Tabel 12	<i>Implementasi Kelas</i>	44
Tabel 13	<i>Deskripsi Implementasi Antarmuka Homepage</i>	45
Tabel 14	<i>Deskripsi Implementasi Antarmuka Add Review</i>	47
Tabel 15	<i>Deskripsi Implementasi Antarmuka tambahan Insert Review Dataset</i>	48
Tabel 16	<i>Deskripsi Implementasi Antarmuka See Review List</i>	49
Tabel 17	<i>Deskripsi Implementasi Antarmuka Start Duplicate Detection</i>	50
Tabel 18	<i>Deskripsi Implementasi Antarmuka See Spam Candidate</i>	51
Tabel 19	<i>Deskripsi Implementasi Antarmuka Verify Spam Candidate</i>	52
Tabel 20	<i>Deskripsi Implementasi Antarmuka See Review List (Verified)</i>	53
Tabel 21	<i>Source Code mengolah Teks JSON untuk penyiapan review</i>	53
Tabel 22	<i>Source Code Penghapusan Stopword dan Deteksi Duplikat</i>	57
Tabel 23	<i>Source Code untuk verifikasi review</i>	59
Tabel 24	<i>Hasil Pengujian Aplikasi</i>	63
Tabel 25	<i>Review Spam duplikat sebelum Verifikasi</i>	65
Tabel 26	<i>Review Spam Duplikat setelah Verifikasi</i>	66
Tabel 27	<i>Sampel Data Review Produk Amazon</i>	70

BAB I

PENDAHULUAN

1.1 Latar Belakang

Web telah mengubah bagaimana orang-orang berekspresi dan berinteraksi. Orang-orang dapat menulis *review* atas apa saja di dalamnya. Sebagai contoh yang telah banyak dilakukan yaitu banyak orang mencari *review* sebuah produk atau jasa dengan tujuan memutuskan menggunakannya atau tidak, terlebih dari itu banyak juga opini atau komentar dari berbagai pengguna yang juga mengulas barang atau jasa terkait yang juga menjadi referensi bagi pembaca. Tidak hanya itu, kalangan lain seperti produsen produk atau jasa tersebut juga dapat mengetahui bagaimana opini pengguna mengenai produk dan jasa yang mereka tawarkan.

Tumbuh pesatnya media sosial, yang seperti *review*, diskusi forum, blog, jejaring sosial dan sebagainya membuat banyak perorangan atau organisasi menggunakan opini publik untuk membuat keputusan. Bahkan sistem analisis sentimen otomatis pada *review* produk juga dirancang digunakan untuk menganalisa *review* atau opini pengguna suatu produk yang di-*posting* pada banyak situs *e-commerce*, digunakan untuk mengetahui umpan balik dan tanggapan mereka terhadap produk yang mereka pasarkan.

Namun kontrol kualitas dari suatu *review* yang di-*posting* di dalam situs-situs tersebut pada kenyataannya tidak ada, orang bebas menuliskan apa saja opini yang ingin dituliskannya, sehingga tidak semua opini relevan digunakan untuk mendukung keputusan. Opini yang di-*posting* bisa saja berupa opini spam, yang dapat berasal dari perorangan, grup, atau juga sistem. Bagaimanapun mencari opini dan menentukan spam tidaklah selalu mudah karena begitu banyaknya situs yang beraneka ragam yang biasanya memiliki opini dalam kapasitas yang cukup besar seperti pada blog dan forum. Pembaca juga mengalami kesulitan untuk mengenali opini yang relevan dan akurat terkait tidak semua opini yang ada benar-benar berasal dari pengguna, atau juga karena sistem yang otomatis yang menyesatkan

para pembaca dan juga bisa merugikan pihak penyedia barang dan jasa tersebut. Bahkan dalam sistem analisis sentimen dan penggalian opini otomatis pada *review* produk, dapat menghasilkan analisis yang menyesatkan, jika menganalisa atau menggali informasi dari opini palsu atau opini yang isinya hanyalah iklan promosi dan sebagainya karena *review* ditulis bebas oleh pengguna di situs-situs *e-commerce* tersebut, dimana sistem analisis sentimen dan penggalian opini otomatis pada *review* produk harus menggali *review* atau opini yang benar.

Permasalahan yang dihadapi dalam mengidentifikasi *review* spam dengan hanya membaca *review* adalah cukup sulit karena seorang *spammer* dapat merancang dengan cermat dan hati-hati menulis sebuah *review* spam dan yang terlihat hanya seperti *review* sebagaimana biasanya namun opini tersebut merupakan opini yang mengelabui pembaca.

Salah satu *website e-commerce* yang menjual banyak produk dan memiliki banyak *review* produk disetiap produknya adalah *amazon.com*. Penelitian sebelumnya oleh Nitin Jindal dan Bing Liu menemukan fakta banyak *review* yang memiliki kemiripan pada *review-review* produk didalamnya bahkan sama pada produk yang berbeda atau *review* yang mirip dengan *user* berbeda pada produk yang sama dan lain sebagainya. *Review* tidak normal ini tanpa disadari pembaca hanyalah seperti *review* biasa. Nitin Jindal dan Bing Liu pada penelitiannya meneliti *review* yang ada di *amazon* dan menemukan opini yang duplikat dan mendekati duplikat. Jenis-jenis duplikat tersebut adalah sebagai berikut: (1)Duplikasi dari pembuat opini dengan id yang berbeda pada produk yang sama, (2)Duplikasi dari pembuat opini dengan id yang sama pada produk yang berbeda, dan (3)Duplikasi dari pembuat opini dengan id yang berbeda pada produk yang berbeda.

Penelitian lainnya mengenai penggalian opini juga sedang dilakukan oleh Hilda Widyastuti dan timnya yaitu Penerapan Algoritma *Boosting* untuk Penyelesaian Masalah Ketidakseimbangan kelas dalam deteksi opini spam. Penelitian ini membutuhkan aplikasi untuk menghasilkan data training ulasan

spam duplikat berdasarkan fakta yang ditemukan oleh Nitin Jindal dan Bing Liu untuk pembentukkan model deteksi spam menggunakan algoritma lainnya.

Atas latar belakang tersebut muncullah ide untuk mendeteksi *review* spam dengan berdasarkan jenis-jenis duplikat yang tergolong spam, untuk memudahkan para pembaca baik dalam skala perorangan atau dalam skala organisasi dalam memilah *review*, sehingga didapatkan *review* yang relevan untuk mendukung keputusan serta membantu sistem analisis sentimen dan penggalian opini otomatis untuk *preprocessing* data opini agar menghasilkan informasi penggalian data yang benar atau mendekati benar.

1.2 Rumusan Masalah

Berdasarkan latar belakang yang telah diuraikan sebelumnya, rumusan masalah pada Tugas Akhir ini adalah sebagai berikut :

1. Bagaimana merancang aplikasi yang dapat mendeteksi suatu *review* merupakan spam atau tidak?
2. Bagaimana membangun aplikasi yang mendeteksi suatu *review* merupakan spam atau tidak?
3. Bagaimana menentukan suatu *review* merupakan spam atau tidak?

1.3 Batasan Masalah

Ruang lingkup atau batasan masalah pada Tugas Akhir ini adalah sebagai berikut:

1. *Review* yang dianalisis menggunakan Bahasa Inggris.
2. Mendeteksi spam tipe 1 yang tergolong *review* duplikat.
3. Menggunakan pendekatan atau fitur *review-centric* dengan metode deteksi duplikat dan mendekati duplikat.
4. Menggunakan sampel *dataset review* produk amazon.

1.4 Tujuan Penelitian

Tujuan penelitian ini adalah sebagai berikut :

1. Merancang aplikasi yang dapat mendeteksi suatu *review* merupakan spam atau tidak.
2. Membangun aplikasi yang dapat mendeteksi suatu *review* merupakan spam atau tidak.
3. Menentukan suatu *review* merupakan spam atau tidak.

1.5 Sistematika Penulisan

Sistematika penulisan menggambarkan secara singkat organisasi atau struktur penulisan laporan beserta ringkasan isi dari setiap bagiannya.

BAB I : **Pendahuluan** berisi latar belakang pembuatan aplikasi, rumusan masalah, batasan masalah, tujuan dan sistematika penulisan.

BAB II : **Landasan Teori** berisi teori, metode yang digunakan sebagai dasar atau landasan penelitian.

BAB III : **Analisis dan Perancangan** yang berisi gambaran umum aplikasi, fitur utama perangkat lunak, kebutuhan.

BAB IV : **Implementasi dan Pengujian** yang berisi implementasi kelas dan hasil pengujian.

BAB V : **Kesimpulan dan Saran** berisi kesimpulan dari pembahasan yang telah dilaksanakan pada Bab 3.

BAB II LANDASAN TEORI

2.1 Opini

Sebuah opini (atau opini biasa) adalah sebuah *quintuple* (unit yang terdiri dari lima bagian), $(e_i, a_{ij}, o_{ijkl}, h_k, t_l)$, dimana e_i adalah nama dari sebuah entitas, a_{ij} adalah aspek e_i , o_{ijkl} adalah orientasi opini mengenai aspek a_{ij} dari entitas e_i , h_k adalah *opinion holder* dan t_l adalah waktu kapan *review* diekspresikan oleh h_k . Orientasi opini o_{ijkl} bisa positif, negatif, atau netral, atau dapat diekspresikan dengan level kekuatan atau intensitas. Ketika sebuah opini adalah pada entitasnya sendiri sebagai keseluruhan, maka menggunakan aspek spesial umum untuk menotasikannya (Liu, 2012).

2.2 Opini/Review Spam

Review kaya akan opini pengguna pada produk dan jasa (Jindal & Liu, *Opinion Spam and Analysis*, 2008). *Review* dipakai oleh banyak orang untuk memutuskan membeli suatu produk. Di sisi produsen atau perusahaan manufaktur *review* juga mereka gunakan untuk mengetahui umpan balik mereka terhadap produk mereka atau bahkan informasi terkait kompetitor produk mereka.

Fakta bahwa memang tidak ada kontrol kualitas atas suatu opini/*review*, siapa saja dapat menulis apa saja di web. Sehingga memungkinkan *review* berkualitas rendah atau bahkan tidak dapat dipercaya yaitu *spam* ditulis didalamnya.

Biasanya opini/*review* publik banyak digunakan untuk berbagai tujuan. Contohnya ketika seseorang ingin membeli atau menggunakan suatu barang/jasa yang ditawarkan, mereka melihat *review* para pengguna pada produk tersebut. Jika banyak negatif mereka cenderung melihat produk yang lain, namun jika banyak positif mereka cenderung akan membeli barang tersebut.

“Opinion spam, also called review spam, are reviews that range from simply annoying self-promotions or announcements that have no relationship with the reviewed product to deliberately fraudulent product reviews provided with the

intention of misleading consumers” (Harris, 2012) yang jika diterjemahkan “Opini spam, atau disebut juga dengan *review* spam, merupakan *review* yang isinya lebih kurang mengganggu promosi sendiri atau pengumuman yang tidak ada hubungannya dengan produk yang diulas, sengaja membuat *review* produk yang menipu untuk menyesatkan konsumen.”

Selanjutnya (Liu, 2012) *Opinion Spamming*, merujuk pada aktifitas “ilegal” (misalnya menulis *review* palsu, disebut juga dengan *shilling*), yang mencoba untuk menyesatkan pembaca atau sistem penggali opini dan analisis sentimen otomatis dengan memberikan opini tidak layak, pada beberapa entitas target untuk mempromosikan entitas dan atau memberi opini negatif palsu ke beberapa entitas lainnya untuk merusak reputasi produk tersebut.

Menurut Nitin Jindal dan Bing Liu (Jindal & Liu, *Opinion Spam and Analysis*, 2008) Secara umum ada 3 tipe spam pada *review*, (1) *Tipe 1 : Untruthful Opinion* : merupakan *review* yang sengaja menyesatkan pembaca atau sistem penggali opini, yang memberi *review* positif tidak layak terhadap kepada beberapa objek target dengan tujuan mempromosikan objek (yang disebut dengan *hyper spam*) dan atau dengan memberikan tidak hanya atau *review* negatif jahat ke beberapa objek target untuk menghancurkan reputasinya (disebut juga dengan *defaming spam*); (2) *Tipe 2 : Review Brands Only* : *review* yang hanya membuat *review* yang kontennya tentang suatu *brand* atau merek dan tidak menarget produk secara spesifik. Umumnya produk yang diulas merupakan suatu produk dengan detail. Mengomentari mereknya saja termasuk spam karena tidak spesifik terhadap produk; *Tipe 3 : Non-review* : *Review* yang kontennya bukanlah konten layaknya *review*, seperti iklan dan *review* yang tidak relevan lainnya yang tidak mengandung opini (seperti: pertanyaan, jawaban, atau teks random).

2.3 Tipe Data yang Digunakan untuk Deteksi Review Spam

Menurut Bing Liu (Liu, 2012) ada tiga tipe data yang digunakan saat mendeteksi spam yaitu :

- a. Konten *review*, yaitu konten teks aktual pada setiap *review*.

- b. Meta data sebuah *review*, misalnya *rating* yang diberikan untuk setiap *review*, *user_id* pengulas, waktu saat *review* dibuat, *IP address* *reviewer*, lokasi, urutan klik pada situs *review*.
- c. Informasi produk, yaitu informasi tentang entitas yang sedang diulas, misalnya deskripsi produk dan volume penjualan.

Pada penelitian ini digunakan konten *review* serta meta data *review* seperti waktu *review* dibuat.

2.4 Deteksi Review Spam Tipe 1

Spam tipe 2, dan 3 mudah untuk diidentifikasi secara manual. Permasalahannya yang dihadapi dalam mengidentifikasi *review* spam tipe 1 dengan hanya membaca *review* adalah cukup sulit karena seorang *spammer* dapat merancang dengan cermat dan hati-hati menulis sebuah *review* spam dan yang terlihat hanya seperti *review* biasanya.

Mengidentifikasi spam tipe 1 secara manual adalah sangat sulit. Nitin Jindal dan Bing Liu pada penelitiannya meneliti *review* yang ada di amazon.com dan menemukan *review* yang duplikat dan mendekati duplikat dalam jumlah yang besar didalamnya juga masih terdapat spam tipe 2 dan 3. Mereka mengemukakan bahwa spam tipe 1 merupakan *review* duplikat seperti jenis berikut (Jindal & Liu, Opinion Spam and Analysis, 2008) :

-) Duplikasi dari pembuat *review* dengan id yang berbeda pada produk yang sama
-) Duplikasi dari pembuat *review* dengan id yang sama pada produk yang berbeda.
-) Duplikasi dari pembuat *review* dengan id yang berbeda pada produk yang berbed (id user berbeda namun bisa saja dengan orang yang sama).

Menurut Jindal dan Bing Liu *review* yang duplikat dari pembuat *review* dengan id yang sama pada produk yang sama tidak digolongkan ke dalam spam. Seperti misalnya pengulas tidak sengaja menekan klik lebih dari satu kali saat memasukkan *review*-nya.

Review yang merupakan duplikasi *review* lain atau mendekati duplikasi *review* lain dianggap spam. Deteksi duplikasi atau mendekati duplikat dilakukan menggunakan metode *shingle*. Perhitungan kesamaan dilakukan dengan *Jaccard distance*. Pasangan yang mempunyai tingkat persamaan minimal 90% dianggap sebagai pasangan *review* yang duplikat.

2.5 Deteksi Duplikat dan mendekati Duplikat

Review duplikat dapat didefinisikan sebagai *review* yang sama persis dan *review* mendekati duplikat merupakan *review* yang mirip sebahagian (persentase kesamaan similaritas dibawah variasi pertimbangan). Fungsi similaritas ini digunakan untuk mendefinisikan kesamaan antara 2 objek secara kuantitatif. Fungsi similaritas mengembalikan nilai [0,1] yang bergantung pada derajat kesamaan antara dua objek. Semakin tinggi derajat kesamaan antara dua objek dianggap mendekati duplikat. Ambang batas juga ditentukan untuk mengidentifikasi apakah derajat similaritas yang dipertimbangkan untuk objek yang mendekati duplikat. Semua pasangan objek tersebut ditemukan dengan fungsi *join similarity* dan menggunakan ambang. Ada banyak fungsi similaritas. Pada penelitian ini akan digunakan algoritma PPJoin untuk deteksi mendekati duplikat.

Pada tahap ini algoritma PPJoin dipakai untuk mendeteksi duplikat dan mendekati duplikat. *Review* yang telah melalui tahap penghapusan *stop-word* kemudian digunakan sebagai input kedalam algoritma ppjoin dengan ambang t yang sudah didefinisikan. Suatu *review* dikatakan mendekati duplikat jika memiliki nilai similaritas lebih besar daripada t . Algoritma *PPjoin* menggunakan fungsi similaritas *Jaccard* untuk menghasilkan kandidat pasangan *review* yang memiliki kemungkinan besar mendekati duplikat.

Fungsi similaritas *Jaccard* :

$$J(x, y) = \frac{|x \cap y|}{|x \cup y|} \geq t$$

Dimana x dan y adalah daftar *review* yang sudah dikanonikalisasi, t adalah ambang untuk fungsi similaritas *Jaccard*, ambang yang sama juga digunakan untuk algoritma *PPJoin*. Nilai similaritas dari dua *review* adalah rasio dari irisan dari 2-gram *review* tersebut terhadap gabungan dari 2-gram *review* tersebut.

2.6 Dataset Review Produk Amazon

Amazon.com merupakan salah satu toko *online* terbesar di dunia yang menyediakan berbagai jenis produk baik berupa produk manufaktur, audio dan CD, serta berbagai buku. Di website ini banyak sekali terdapat *review* pada tiap produknya. Deskripsi lebih lanjut *dataset review* amazon sebagai berikut :

2.6.1 Sumber Dataset

Dataset review pada data *review* amazon yang diambil pada *website* Julian MC Auley, UCSD (<http://jmcauley.ucsd.edu/data/amazon/>) mencakup *review* sejak Mei 1996 hingga Juli 2014 yang hanya dapat digunakan untuk keperluan penelitian.

2.6.2 Berkas Dataset

Berkas *review* tersebut berformat JSON. *Review* lengkap ada dalam berkas `complete.json.gz` berukuran 20 GB yang kemudian diekstrak menjadi 92,5 GB. Setiap *review* amazon.com terdiri dari 8 bagian. Adapun contoh konten berkas *review* tersebut adalah sebagai berikut :

```
{ "reviewerID": "A2SUAM1J3GNN3B", "asin": "0000013714", "reviewerName": "J. McDonald", "helpful": [2, 3], "reviewText": "I bought this for my husband who plays the piano. He is having a wonderful time playing these old hymns. The music is at times hard to read because we think the book was published for singing from more than playing from. Great purchase though!", "overall": 5.0, "summary": "Heavenly Highway Hymns", "unixReviewTime": 1252800000, "reviewTime": "09 13, 2009" }
```

Dimana :

) reviewerID - ID *reviewer* (pengulas) misalnya : A2SUAM1J3GNN3B

) asin - *Amazon Standard Identification Number* (Wikipedia, 2013), ID produk, misalnya : 0000013714

-) reviewerName - nama *reviewer*
-) helpful - *rating* yang membantu, misalnya 2/3
-) reviewText - teks *review*
-) overall - *rating* produk
-) summary - kesimpulan *review*
-) unixReviewTime - waktu *review* (waktu unik)
-) reviewTime - waktu *review* (secara kasar/tanggal)

BAB III ANALISIS DAN PERANCANGAN

3.1 Deskripsi Umum Sistem



Gambar 1 Deskripsi Umum Sistem Aplikasi

Gambar 1 menggambarkan mengenai proses kerja deteksi *review* spam. Untaian proses kerja aplikasi ini dimulai dengan pengguna menginput data *review* produk, yaitu berupa *reviewerID* (id *reviewer*), *asin* (*Amazon Standard Identification Number* atau ID produk), *reviewerName* (nama *reviewer*), *reviewText* (konten/teks *review*) dan *unixReviewTime* (waktu *review* (unik)) melalui aplikasi dan data tersebut disimpan ke dalam *database* kemudian pengguna mengaktifkan berbagai proses analisis yaitu deteksi duplikat dan verifikasi kandidat *review* duplikat dimana setiap proses aplikasi menganalisa pengguna dan *review* pada produk, dan menampilkan *output* kandidat *review* spam, dan ulasan spam dan non-spam yang telah terverifikasi.

3.2 Karakteristik Pengguna Aplikasi

Secara umum karakteristik pengguna aplikasi ini adalah sebagai berikut :

1. Mengetahui struktur JSON (Mengikuti prosedur pengolahan data).
2. Mengetahui struktur *query database* (opsional dalam sebagian kecil fungsi).

3.3 Kebutuhan Fungsional

Kebutuhan fungsional perangkat lunak aplikasi ini adalah sebagai berikut :

1. Aplikasi dapat menyimpan *dataset review* yang diinput pengguna.
2. Aplikasi dapat melakukan penghapusan *stop-word* pada *review*.
3. Aplikasi dapat menghitung nilai similaritas tiap pasangan *review*.
4. Aplikasi dapat mendeteksi *review* spam tipe 1.
5. Aplikasi dapat memverifikasi *review* duplikat namun bukan spam.
6. Aplikasi dapat menampilkan hasil deteksi berupa *review* yang tergolong sebagai spam tipe 1.

3.4 Non-Fungsional

Kebutuhan non-fungsional pada aplikasi ini adalah sebagai berikut :

1. Cara penggunaan aplikasi dapat dimengerti pengguna.
2. Antar muka aplikasi *user-friendly*

3.5 Batasan Sistem

Aplikasi ini memiliki batasan sistem untuk dapat dijalankan, batasan sistem tersebut dapat dilihat pada tabel berikut :

Tabel 1 Batasan Sistem Hardware, Software, dan Perangkat Pengembang

Perangkat	Hardware	Software	Perangkat Pengembang
Laptop / PC	1. RAM minimal 4GB 2. Processor min Intel Core I3 (2.2 GHz.)	1. OS Windows 7 2. Internet Explorer 11	1. Bahasa Pemrograman ASP.NET C# (web) 2. Visual Studio 2013 3. Microsoft SQL Server Management Tool R2 4. Microsoft SQL Server 5. JSON.NET.

3.6 Arsitektur Deteksi *Review* Spam Tipe 1

Berdasarkan metode deteksi *review* spam tipe 1 yang telah dibahas pada landasan teori, dirancang sebuah arsitektur untuk mendeteksi spam tersebut.

Arsitektur untuk deteksi spam tipe 1 dengan deteksi duplikat dan mendekati duplikat sebagai berikut :



Gambar 2 Arsitektur Deteksi *Review* Spam Tipe 1

Alur Arsitektur deteksi *review* spam tipe 1 kedalam 4 langkah proses sebagai berikut yaitu: (1)Penyiapan *Review*, (2)Penghapusan *Stop-word*, (3)Deteksi duplikat dan mendekati duplikat, dan (4)Verifikasi kandidat spam

3.6.1 Penyiapan *Review*

Penyiapan *review* merupakan tahap yang bertujuan untuk mempersiapkan data agar format sesuai dengan kebutuhan proses selanjutnya. Karena data sampel *review* yang digunakan merupakan *dataset review* dari *website* amazon.com yang berupa teks berformat JSON seperti yang telah dijelaskan pada bagian 2.6.2, data yang ada dipersiapkan dengan rangkaian langkah-langkah berikut :

1. Berkas *review* dibuka dengan aplikasi notepad++ .
2. *Review* dipotong (karena berkas datanya sangat besar) kemudian dibuka kedalam aplikasi pengolah teks lainnya, Hal ini dilakukan karena format JSON berkas *review* akan diubah menjadi bentuk yang dapat dikonversi kedalam bentuk tabel. Untuk itu perlu dilakukan perubahan sebagai berikut :
 - a. Karakter '[' ditambahkan diawal potongan *review* dan karakter ']' pada akhir *review*.

Contoh :

Potongan *review* sebagai berikut :

```
{ "reviewerID": "A10AYO08J5FSMK", "asin": "1590309413", "reviewerName":  
  "Vincent Kan", "helpful": [1, 2], "reviewText": "This is a  
  wonderful book. I read four times ahead. Great book I ever  
  use for rest of life.", "overall": 5.0, "summary": "Great Book  
  on Communication!", "unixReviewTime": 1393286400, "reviewTime":  
  "02 25, 2014"}  
{ "reviewerID": "A10AYO35L9P7ZR", "asin": "B009PCBEPE", "reviewerName":  
  "Liam Carrigan", "helpful": [0, 0], "reviewText": "I got the app  
  on Christmas day (which was the day when I got my kindle fire HD)  
  and I couldn't let go of my tablet. After 2 hours I couldn't even  
  blink my eyes for a whole 30 minutes.", "overall": 5.0, "summary":  
  "best game ever!!!!:)", "unixReviewTime": 1370304000,  
  "reviewTime": "06 4, 2013"}
```

Menjadi (lihat penambahan karakter dengan warna *font* merah) :

```
[{ "reviewerID": "A10AYO08J5FSMK", "asin": "1590309413",  
  "reviewerName": "Vincent Kan", "helpful": [1, 2], "reviewText":  
  "This is a wonderful book. I read four times ahead. Great  
  book I ever use for rest of life.", "overall": 5.0,  
  "summary": "Great Book on Communication!", "unixReviewTime":  
  1393286400, "reviewTime": "02 25, 2014"}  
{ "reviewerID": "A10AYO35L9P7ZR", "asin": "B009PCBEPE", "reviewerName":  
  "Liam Carrigan", "helpful": [0, 0], "reviewText": "I got the app  
  on Christmas day (which was the day when I got my kindle fire HD)  
  and I couldn't let go of my tablet. After 2 hours I couldn't even  
  blink my eyes for a whole 30 minutes.", "overall": 5.0, "summary":  
  "best game ever!!!!:)", "unixReviewTime": 1370304000,  
  "reviewTime": "06 4, 2013"}]
```

b. Karakter “}” menjadi “},”

Contoh :

```
[{ "reviewerID": "A10AYO08J5FSMK", "asin": "1590309413",  
  "reviewerName": "Vincent Kan", "helpful": [1, 2], "reviewText":  
  "This is a wonderful book. I read four times ahead. Great  
  book I ever use for rest of life.", "overall": 5.0,  
  "summary": "Great Book on Communication!", "unixReviewTime":  
  1393286400, "reviewTime": "02 25, 2014"},  
{ "reviewerID": "A10AYO35L9P7ZR", "asin": "B009PCBEPE", "reviewerName":  
  "Liam Carrigan", "helpful": [0, 0], "reviewText": "I got the app  
  on Christmas day (which was the day when I got my kindle fire HD)  
  and I couldn't let go of my tablet. After 2 hours I couldn't even  
  blink my eyes for a whole 30 minutes.", "overall": 5.0, "summary":  
  "best game ever!!!!:)", "unixReviewTime": 1370304000,  
  "reviewTime": "06 4, 2013"},]
```

c. Penghapusan karakter ‘,’ pada karakter ‘}’ *review* terakhir (sebelum tanda ‘]’)

Contoh:

Sebelum (perhatikan karakter dengan di-mark dengan warna kuning) :

```
[{"reviewerID": "A10AYO08J5FSMK", "asin": "1590309413",
  "reviewerName": "Vincent Kan", "helpful": [1, 2], "reviewText":
  "This is a wonderful book. I read four times ahead. Great
  book I ever use for rest of life.", "overall": 5.0,
  "summary": "Great Book on Communication!", "unixReviewTime":
  1393286400, "reviewTime": "02 25, 2014"},
{"reviewerID": "A10AYO35L9P7ZR", "asin": "B009PCBEPE", "reviewerName":
  "Liam Carrigan", "helpful": [0, 0], "reviewText": "I got the app
  on Christmas day (which was the day when I got my kindle fire HD)
  and I couldn't let go of my tablet. After 2 hours I couldn't even
  blink my eyes for a whole 30 minutes.", "overall": 5.0, "summary":
  "best game ever!!!!)", "unixReviewTime": 1370304000,
  "reviewTime": "06 4, 2013"}]
```

Sesudah:

```
[{"reviewerID": "A10AYO08J5FSMK", "asin": "1590309413",
  "reviewerName": "Vincent Kan", "helpful": [1, 2], "reviewText":
  "This is a wonderful book. I read four times ahead. Great
  book I ever use for rest of life.", "overall": 5.0,
  "summary": "Great Book on Communication!", "unixReviewTime":
  1393286400, "reviewTime": "02 25, 2014"},
{"reviewerID": "A10AYO35L9P7ZR", "asin": "B009PCBEPE", "reviewerName":
  "Liam Carrigan", "helpful": [0, 0], "reviewText": "I got the app
  on Christmas day (which was the day when I got my kindle fire HD)
  and I couldn't let go of my tablet. After 2 hours I couldn't even
  blink my eyes for a whole 30 minutes.", "overall": 5.0, "summary":
  "best game ever!!!!)", "unixReviewTime": 1370304000,
  "reviewTime": "06 4, 2013"}]
```

d. Ubah karakter petik (‘) menjadi “. Ini dilakukan agar pembuatan *query insert* tidak bermasalah.

Contoh :

Sebelum : I couldn't , sesudah : I couldn`t

d. Kunjungi *website* <http://json2table.com/> gunakan aplikasi tersebut untuk merubah JSON menjadi tabel, seperti gambar berikut :

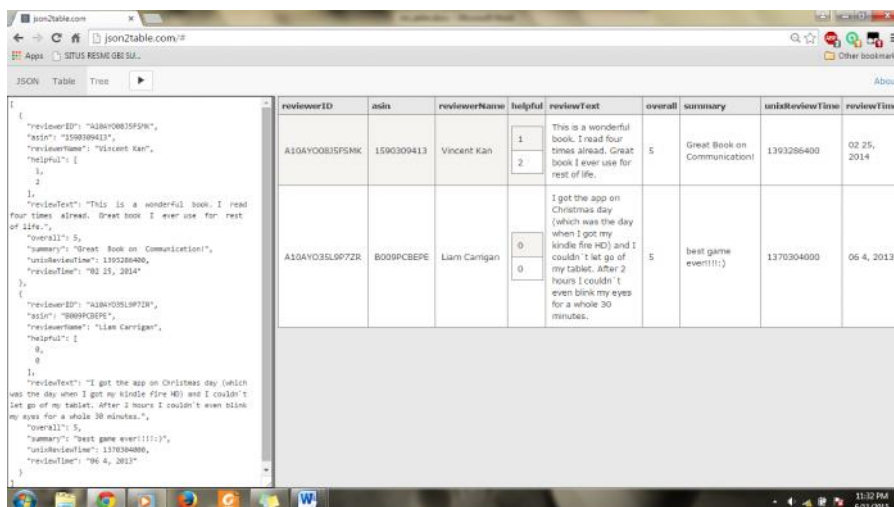

Gambar 3.3 Script JSON yang dikonversi menjadi table

- e. Tabel pada halaman tersebut
- f. di-*block* dan di-*copy* kemudian dimasukkan kedalam aplikasi Microsoft Excel tersebut. Selanjutnya hapus kolom *helpful*, *overall*, *summary*, dan *review time*. Data tersebut kemudian dipilah kedalam 3 *worksheet*, pertama untuk data produk (*asin*), kedua untuk data *reviewer* (*reviewerID* dan *reviewerName*), ketiga untuk data *review*. Pada data produk dan *reviewer* duplikasinya dibuang dengan fungsi “*remove duplicates*” (pada Tab Data → *Remove Duplicates*) kemudian query *insert* dibuat dengan fungsi sebagai seperti pada gambar berikut :

	A	B
1	DOS2.dbo.Product	
2	asin	
3	6428320	= "insert into DOS2.dbo.Product values('" & A3 & "');"
4	14072149	insert into DOS2.dbo.Product values('14072149');
5	41291905	insert into DOS2.dbo.Product values('41291905');
6	41913574	insert into DOS2.dbo.Product values('41913574');
7	201891859	insert into DOS2.dbo.Product values('201891859');
8	577088726	insert into DOS2.dbo.Product values('577088726');

Gambar 3.4 Fungsi untuk menghasilkan insert query

Selanjutnya juga dilakukan pembuatan *query insert* untuk data *reviewer* dan *review* dengan nama tabel DOS2.dbo.Reviewer untuk *reviewer* dan tabel DOS2.dbo.Review untuk *review*.

3.6.2 Penghapusan *Stop-word*

Stop-words adalah kata umum (*common words*) yang biasanya muncul dalam jumlah besar dan dianggap tidak memiliki makna . Contoh stop words untuk bahasa Inggris diantaranya “*of*”, “*the*” (Wibisono, 2008).

Agar tidak menimbulkan kerancuan dalam proses pengolahan dokumen, *stop-word* harus dibuang. Setelah tahap persiapan data, *stop-word* yang ada pada konten *review* akan dihapus.

StopwordTool (dari situs <http://www.dotnetperls.com/stopword-dictionary>) digunakan sebagai *stopword removal* untuk menghapus *stopword* tersebut. Daftar *review* dijadikan sebagai input kedalam fungsi *remove_stopword*. Setiap isi *review* ditokenisasi terlebih dahulu dan kemudian irisan dari daftar token *review*

dengan daftar *stopword* akan dihapus dari *review*. Pada akhirnya akan mengembalikan *review* yang telah dihapus *stopword*-nya. Kata-kata yang dikembalikan berupa kata-kata yang sudah unik serta semua dalam bentuk *lower-case* (tidak ada pengulangan, *stopword* dihapus, dan kata-kata yang bukan *stopword* hanya akan muncul satu kali saja, dan ditulis dengan huruf kecil). Berikut potongan *source code c#* yang melakukan *stopword removal* dari sebuah *string* (konten *review*).

```
string RemoveStopwords(string input)
{
    // 1
    // Split parameter into words
    var words = input.Split(_delimiters,
        StringSplitOptions.RemoveEmptyEntries);
    // 2
    // Allocate new dictionary to store found words
    var found = new Dictionary<string, bool>();
    // 3
    // Store results in this StringBuilder

    StringBuilder builder = new StringBuilder();
    // 4
    // Loop through all words
    foreach (string currentWord in words)
    {
        // 5
        // Convert to lowercase
        string lowerWord = currentWord.ToLower();
        // 6
        // If this is a usable word, add it
        if (!_stops.ContainsKey(lowerWord) &&
            !found.ContainsKey(lowerWord))
        {
            builder.Append(currentWord).Append(' ');
            found.Add(lowerWord, true);
        }
    }
    // 7
    // Return string with words removed
    return builder.ToString().Trim();
}
```

Untuk daftar *stopword* (kamus *stopword*) tersebut dapat dilihat pada lampiran daftar *stop-word*. Selanjutnya proses penghapusan *stop-word* dapat dilihat pada contoh berikut :

Contoh 1: Misal R1 dan R2 masing-masing merupakan *review*.

Sebelum penghapusan *stop-word* konten *review* :

R1 = “*I really like this book, this book is inspired , I love to read it*”

R2 = “*When I read the fifth section, I feel bored, such a boring book*”

Setelah penghapusan *stop-word*

R1 = “*really like book inspired love read*”

R2 = “*read fifth section feel bored boring book*”

3.6.3 Deteksi duplikat dan mendekati duplikat

Pada tahap ini algoritma *PPJoin* dipakai untuk mendeteksi duplikat dan mendekati duplikat. Menggunakan fungsi similaritas *Jaccard* dan nilai ambang ditentukan terlebih dahulu.

Contoh 2: Misal $t=0,9$ dan menggunakan R1 dan R2 sebagai *review* yang sudah melalui proses *stopword*.

R1 = “*really like book inspired love read*”

R2 = “*read fifth section feel bored boring book*”

Selanjutnya *review* R1 dan R2 sebagai himpunan dimana kata-kata didalamnya merupakan elemen dari himpunan masing masing.

R1 = {*really, like, book, inspired, love, read*}

R2 = {*read, fifth, section, feel, bored, boring, book*}

Kalkulasi Irisan dan gabungan antara himpunan R1 dan R2 :

$$R1 \cap R2 = \{book, read\}$$

$$R1 \cup R2 = \{really, like, book, inspired, love, read, fifth, section, feel, bored\}$$

Jumlah elemen $R1 \cap R2$ yaitu $|R1 \cap R2| = 2$, dan Jumlah elemen $R1 \cup R2$ yaitu $|R1 \cup R2| = 11$.

Kemudian akan dipakai untuk menghitung skor similaritas *Jaccard*.

$$J(R1, R2) = \frac{2}{11} = 0.1818181818181818$$

Karena $J(R1, R2) < 0.9$ maka R1 dan R2 bukanlah *review* duplikat atau bukan *review* yang mendekati duplikat.

Dalam membuat pasangan *review* dilakukan dengan membuat kombinasi antar id *review*. Karena pada data id *review* tidak ada maka id *review* dibuat secara otomatis yaitu *auto increment*. Untuk menghitung irisan dan gabungan dengan parameter konten *review* berupa string yang emudian akan dipilah menjadi kata perkata dapat menggunakan library LINQ pada C# menggunakan fungsi *intersect* dan *union*.

3.6.4 Verifikasi Kandidat Spam

Setelah kandidat *review* yang memiliki skor similaritas minimal 90% maka dicek kembali waktu *review* dibuat apakah sama antara dua *review* tersebut (akibat tidak sengaja mengklik *mouse* lebih dari satu kali) oleh user yang sama dan pada produk yang sama, maka duplikat ini salah satunya dapat diabaikan.

Contoh 3: Misal Ra dengan Rb, Rc dengan Re merupakan pasangan *review* duplikat (memiliki nilai similaritas $> = 0.9$)

Meta data tiap *review* (pada tabel ini isi konten *review* diabaikan karena sudah diketahui pasangan *review* yang duplikat):

Tabel 2 Metadata Review (contoh)

<i>id review</i>	<i>Asin</i>	<i>reviewerID</i>	<i>unixReviewTime</i>
Ra	A153V2QD4BJT1Z	0739003755	1364083200
Rb	A153V2QD4BJT1Z	0739003755	1364083200
Rc	A0001528BGUBOEV6T5U	B0055Q2VNI	1362873600
Rd	A0001528BGUBOEV6T5U	B0055Q2VS8	1362873600

Selanjutnya mulai dibandingkan kesamaan nilai metadata antar pasangan *review*. Pada tahap ini akan dibandingkan secara berurutan kesamaan antara *unixReviewTime*, jika sama maka produk (*asin*), dan *reviewerID*. Untuk kejadian “*true*” atau benar terjadi maka dinotasikan dengan 1 sedangkan untuk “*false*” maka dinotasikan dengan 0. Setelah semuanya selesai maka kesamaan antara *unixReviewTime*=1 kemudian Kesamaan *asin*= 1 dan Kesamaan *asin*=1 maka, *review* tersebut diabaikan dari spam(tidak dianggap sebagai spam), sedangkan jika ada nilai metadata yang berbeda dari *unixReviewTime*, *asin*, dan *reviewerID* maka tetap dimasukkan sebagai *review* spam. Berikut hasil perbandingan pasangan *review* Ra dengan Rb dan Rc dengan Rd :

Tabel 3 Perbandingan Kesamaan nilai metadata pasangan review.

Pasangan <i>review</i>	Kesamaan <i>Content</i>	Kesamaan <i>unixReviewTime</i>	Kesamaan <i>asin</i>	Kesamaan <i>reviewerID</i>	Dianggap sebagai Spam
Ra, Rb	1	1	1	1	0
Rc, Rd	1	1	1	0	1

Pasangan Rc, Rd memenuhi bentuk duplikat yang tergolong spam tipe 1 yaitu Duplikat dari user berbeda pada produk yang sama maka Rc dan Rd dianggap sebagai spam.

Algoritma untuk verifikasi kandidat spam, dapat dilihat pada tabel berikut :

Tabel 4 *Algoritma Verifikasi Kandidat Spam*

Algoritma verifikasi kandidat spam
sum_review_pair : int ; {total review}
ReviewPair[] a \leftarrow new ReviewPair[sum_review]; {array of review}
for (int i \leftarrow 0; i < sum_review; i++)
do
if (a[i].Sim_UnixReviewTime == 1 and a[i].Sim_asin == 1
and a[i].Sim_Reviewer ==1)
<u>then</u>
a[i].spamclass \leftarrow 0
else
a[i].spamclass \leftarrow 1
<u>end if</u>
<u>end for</u>

3.7 Use Case Diagram

Use Case Diagram Deteksi *Review* Spam pada *Review* Produk ini menggambarkan hubungan sejumlah *external* aktor dengan *Use Case* yang terdapat dalam sistem aplikasi ini. Berikut gambaran *Use Case* Diagram Aplikasi Deteksi *Review* Spam pada *Review* Produk.

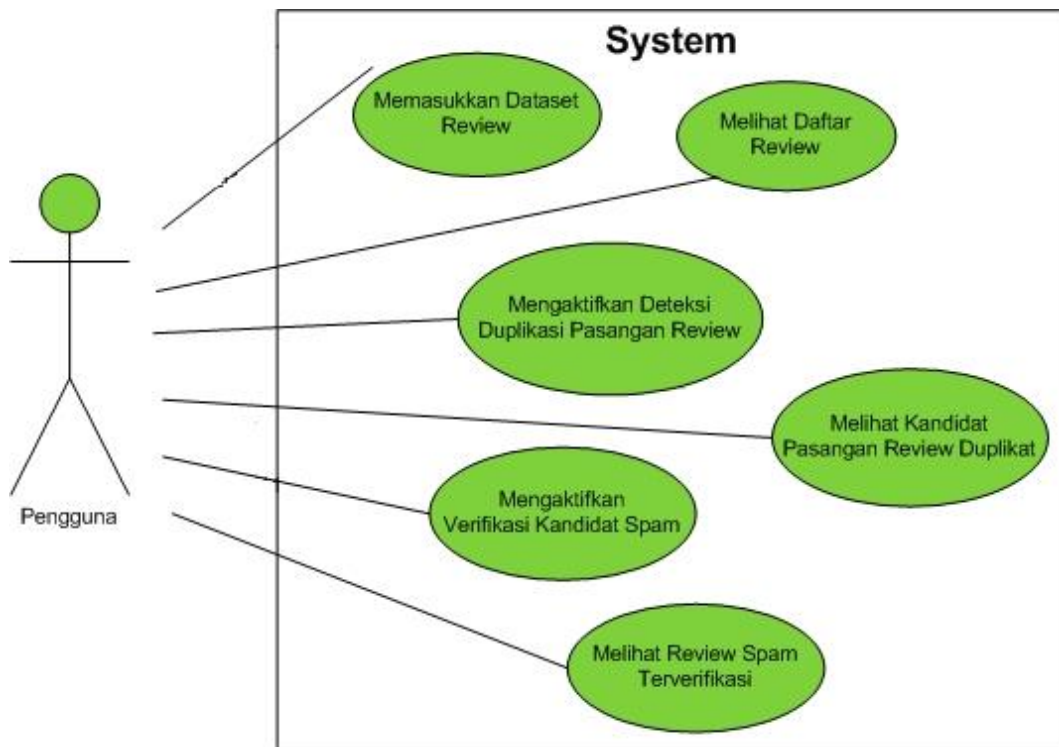

Gambar 3 *Use Case* Deteksi *Review* Spam pada *Review* Produk

3.8 Skenario Use Case

Skenario untuk use case aplikasi ini diuraikan pada subbagian berikut:

3.8.1 Skenario Use Case Memasukkan Data *Review*

Aktor : Pengguna

Kondisi awal : *Dataset* belum terdaftar

Kondisi Akhir : *Dataset* baru sudah terdaftar.

Skenario : Setelah menyiapkan data *review* yang sudah sesuai dengan format deteksi pada aplikasi, pengguna menginput *dataset review* pada halaman form *dataset*.

Skenario Alternatif : Sistem menampilkan pesan “*an error occured*”

3.8.2 Skenario Use Case Melihat Daftar *Review*

Aktor : Pengguna

Kondisi awal : Aktor akan melihat *review*

Kondisi Akhir : *Review* ditampilkan

Skenario : Aktor menuju halaman utama dan memilih menu *See Review List* dan daftar *review* ditampilkan dalam bentuk tabel.

Skenario Alternatif : Sistem menampilkan pesan “*an error occured*”

3.8.3 Skenario Use Case Mengaktifkan Deteksi Duplikasi Pasangan *Review*

Aktor : Pengguna

Kondisi awal : Pasangan *review* belum memiliki skor similaritas

Kondisi Akhir : Pasangan *review* memiliki skor similaritas

Skenario : Aktor menekan tombol “*Detect Duplicate*” pada halaman utama, dan sistem mengkalkulasi skor similaritas tiap pasangan *review*, dan meng-*update* skor similaritas tiap pasangan *review* di *database*.

Skenario Alternatif : Sistem menampilkan pesan “*an error occured*”

3.8.4 Skenario Use Case Melihat Kandidat *Review* Spam

Aktor : Pengguna

Kondisi awal	: Proses deteksi duplikat selesai
Kondisi Akhir	: Kandidat <i>review</i> spam ditampilkan
Skenario	: Pengguna menekan menu “ <i>See Spam Candidate</i> ” dan sistem menampilkan pasangan <i>review</i> yang memiliki nilai similaritas minimal 90%.
Skenario Alternatif	: Sistem menampilkan pesan “ <i>an error occured</i> ”

3.8.5 Skenario Use Case Mengaktifkan Verifikasi Kandidat Spam

Aktor	: Pengguna
Kondisi awal	: Kandidat spam belum diverifikasi
Kondisi Akhir	: Kandidat spam sudah diverifikasi
Skenario	: Pengguna menekan menu “ <i>Verify Spam Candidate</i> ” dan sistem menampilkan pasangan <i>review</i> yang memiliki nilai similaritas minimal 90%.
Skenario Alternatif	: Sistem menampilkan pesan “ <i>an error occured</i> ”

3.8.6 Skenario Use Case Melihat *Review* Spam Terverifikasi

Aktor	: Pengguna
Kondisi awal	: Hasil analisis belum ditampilkan
Kondisi Akhir	: Hasil analisis ditampilkan
Skenario	: Aktor menekan tombol ‘analisis <i>review</i> ’ kemudian sistem mengaktifkan proses analisis, dan proses selanjutnya tombol ‘lihat hasil deteksi’ diaktifkan oleh sistem, aktor menekan tombol tersebut dan sistem menampilkan daftar <i>review</i> spam kepada aktor.

3.9 Sequence Diagram

Diagram menggambarkan urutan proses yang akan terjadi dalam sistem ini. Diagram ini juga menggambarkan *method* yang dijalankan oleh masing-masing kelas setiap proses yang terjadi pada sistem.

3.9.1 Sequence Diagram Use Case Memasukkan Dataset *Review*

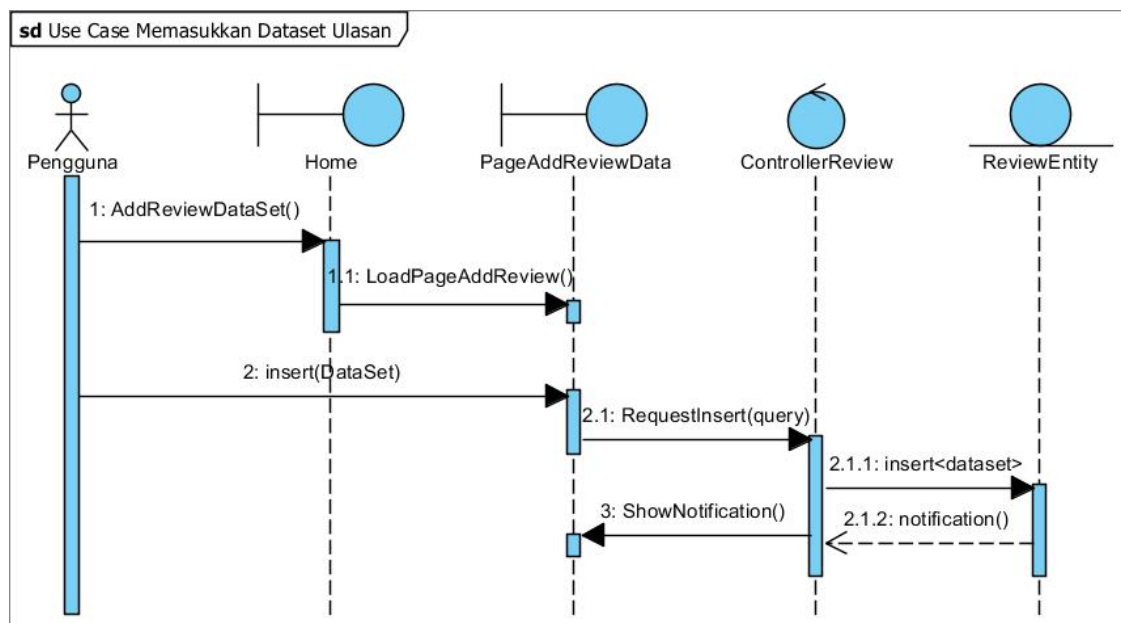

Gambar 4 Sequence Diagram Use Case Memasukkan Dataset *Review*

3.9.2 Sequence Diagram Use Case Melihat Daftar *Review*

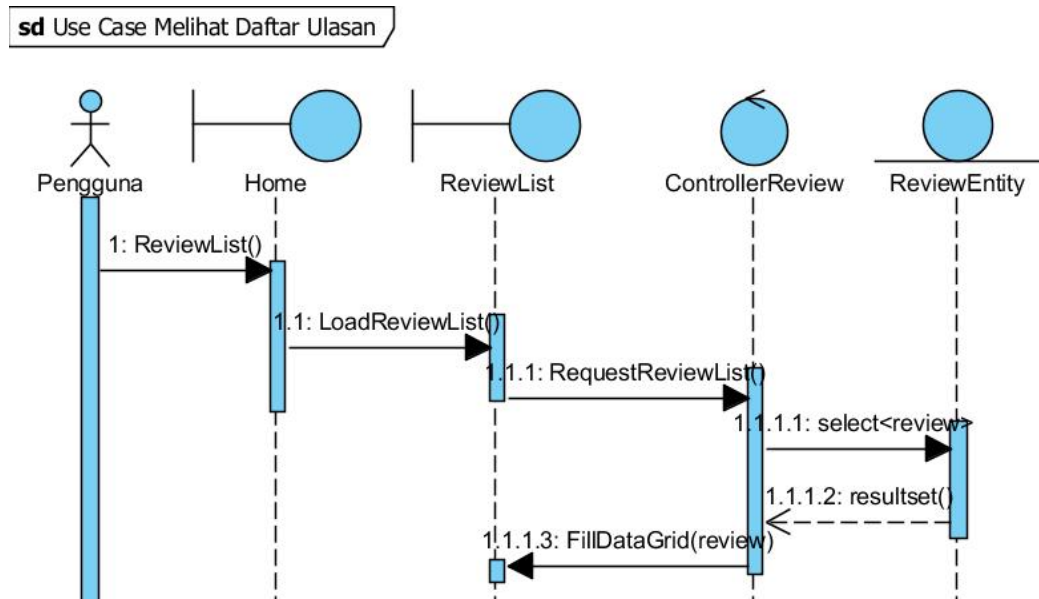

Gambar 5 Sequence Diagram Use Case Melihat Daftar *Review*

3.9.3 Sequence Diagram Use Case Mengaktifkan Deteksi Duplikasi Pasangan *Review*

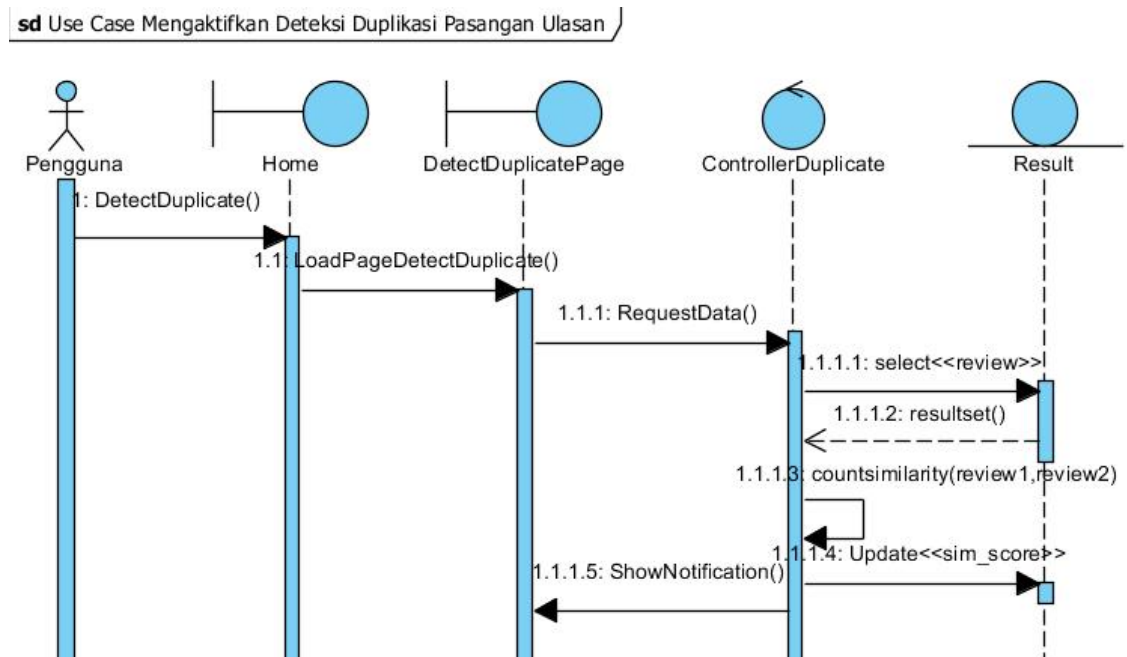

Gambar 6 Sequence Diagram Use Case Mengaktifkan Deteksi Duplikasi Pasangan *Review*

3.9.4 Sequence Diagram Melihat Kandidat Pasangan *Review* Spam

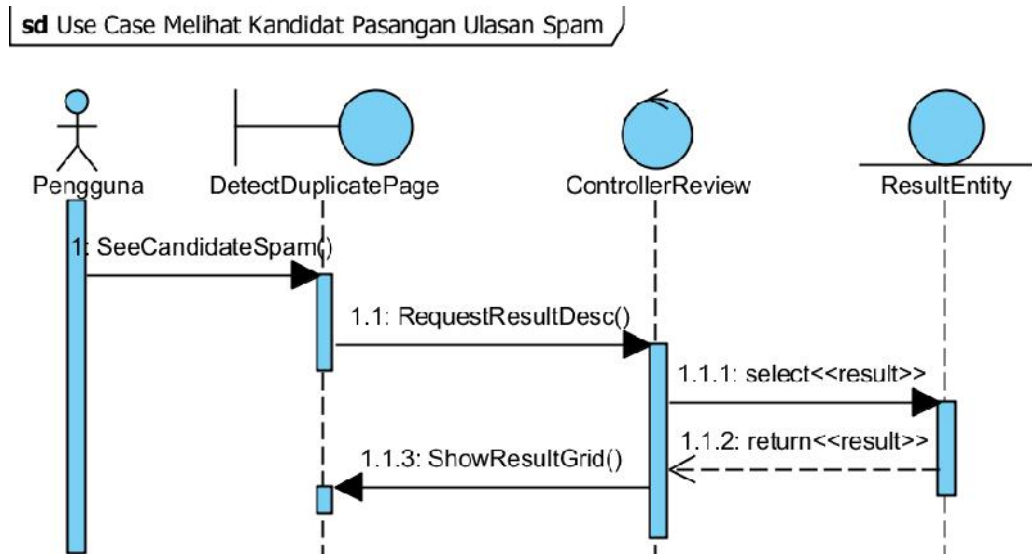

Gambar 7 Sequence Diagram Melihat Kandidat Pasangan *Review* Spam

3.9.5 Sequence Diagram Skenario Use Case Mengaktifkan Verifikasi Kandidat Spam

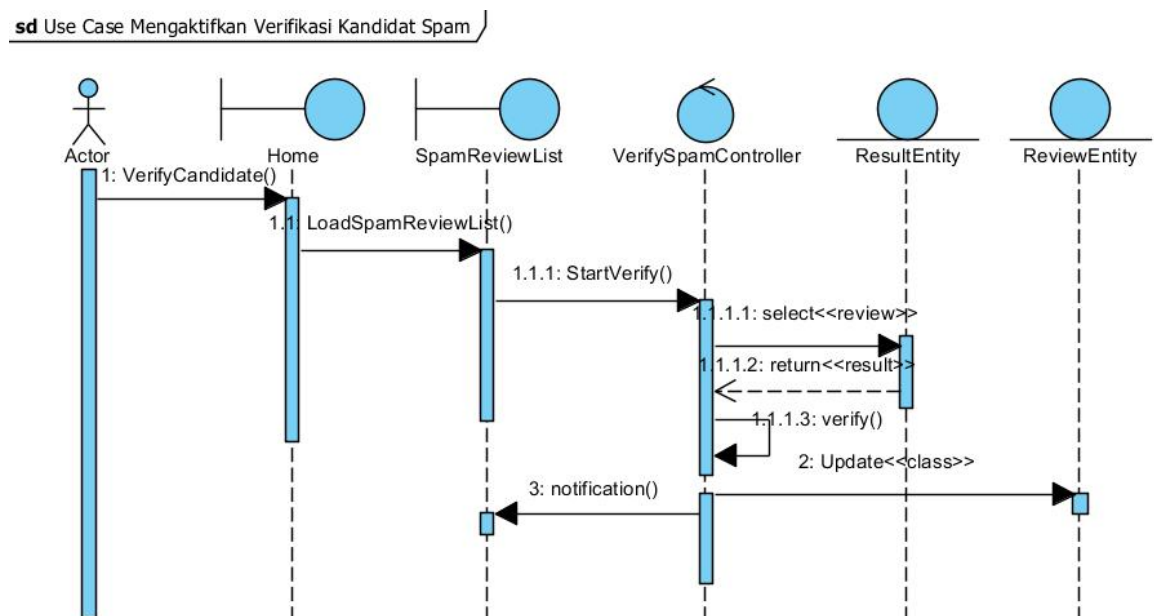

Gambar 8 Sequence Diagram Use Case Mengaktifkan Verifikasi Kandidat Spam

3.9.6 Sequence Melihat *Review* Spam Terverifikasi

sd Use Case Melihat Ulasan Spam Terverifikasi

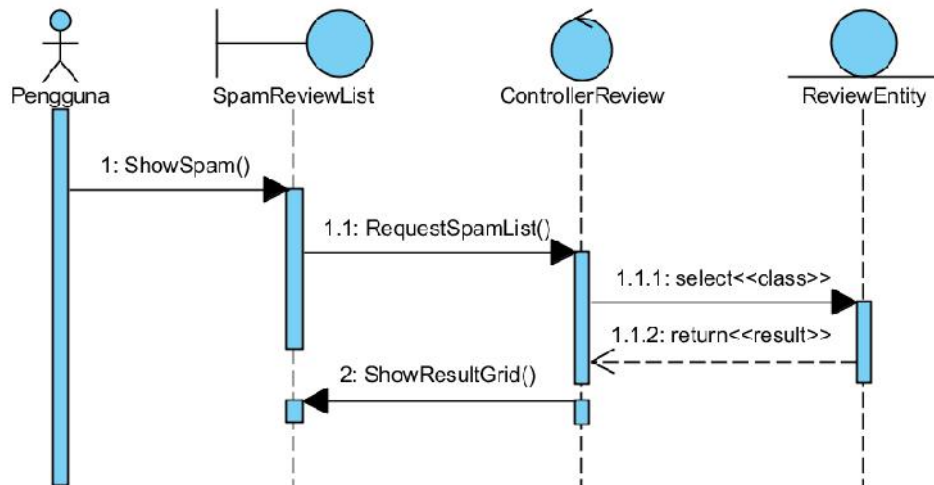

Gambar 9 Sequence Diagram Melihat *Review* Spam Terverifikasi

3.10 Class Diagram

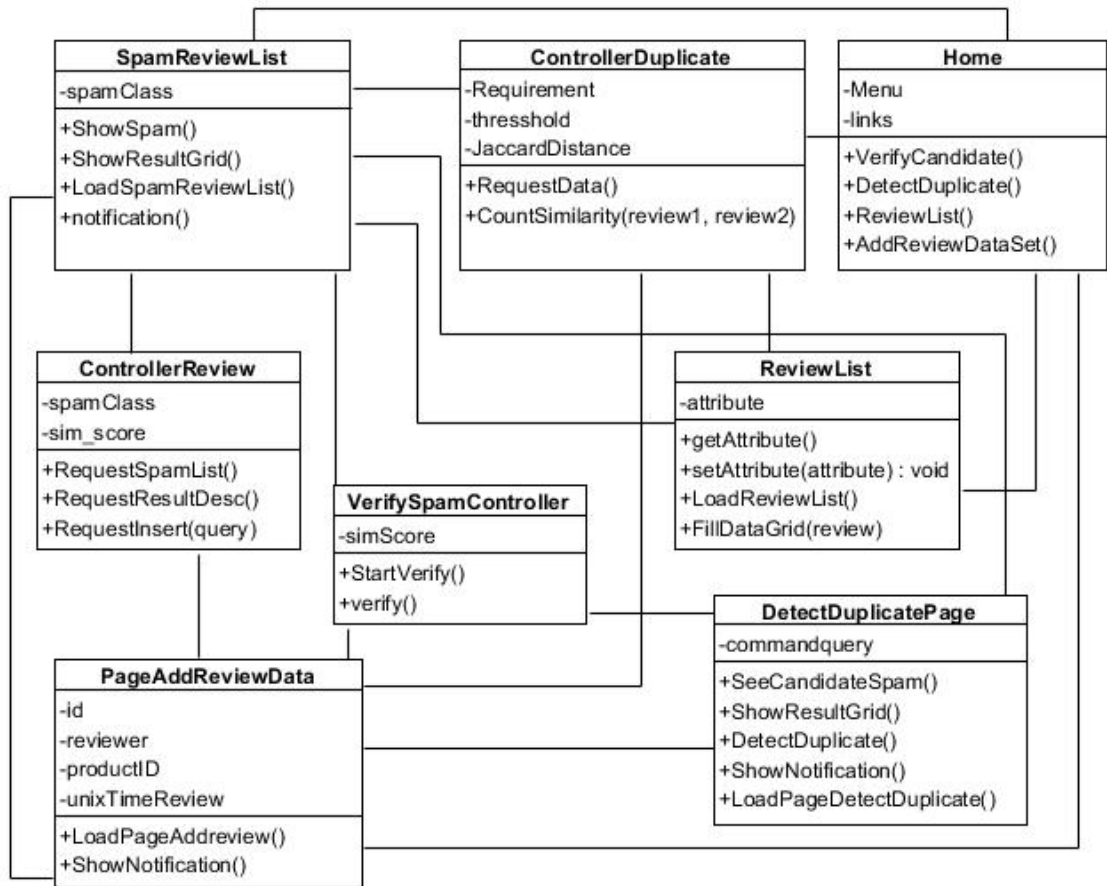

Gambar 10 Class Diagram Deteksi Review Spam

3.11 Perancangan Basis Data

3.11.1 Entity Relationship Diagram

Rancangan *Entity Relationship* pada aplikasi ini diuraikan pada gambar berikut :

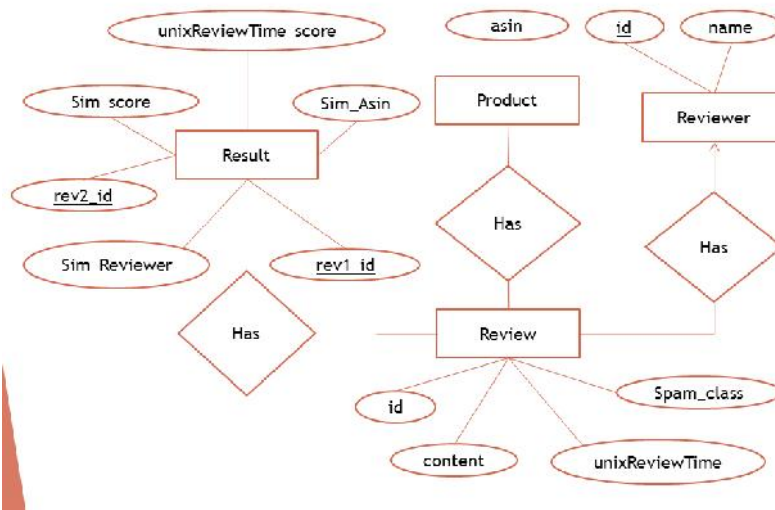

Gambar 11 Entity Diagram Relationship Deteksi Review Spam pada Review Produk

3.11.2 Desain Basis Data

Desain Basis Data pada aplikasi ini diuraikan pada diagram berikut :

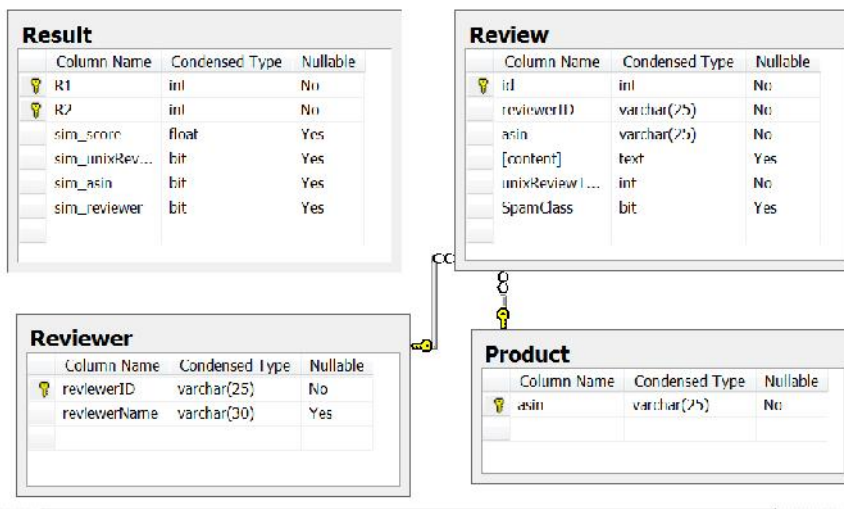

Gambar 12 Desain Basis Data Deteksi Review Spam pada Review Produk

3.12 Perancangan Antarmuka

Perancangan Antarmuka Deteksi *Review* Spam pada *Review* Produk ini diuraikan pada sub-bagian berikut :

3.12.1 Antarmuka *Homepage*

Antarmuka *homepage* merupakan halaman yang pertama kali muncul saat aplikasi dijalankan. Halaman ini menyajikan berbagai menu yang dapat dipilih dengan mengklik tombol menu yang ada pada halaman ini.

Review Spam Detection

A web-based Application for detecting spam review on product

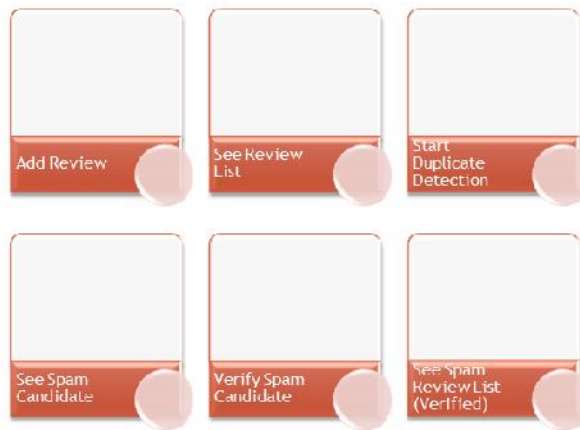

Gambar 13 Rancangan Antarmuka *Homepage*

Deskripsi rancangan antarmuka *Homepage* diuraikan pada tabel berikut :

Tabel 5 Deskripsi Rancangan Antarmuka *Homepage*

Item	Fungsi
<i>Button Add Review</i>	Menuju halaman <i>Add Review</i> untuk menambahkan <i>review</i> ke daftar <i>Review</i>
<i>Button See Review List</i>	Menuju halaman <i>See Review List</i> untuk melihat daftar <i>review</i> yang sudah ada.
<i>Button Start</i>	Menuju halaman <i>Start Duplicate Detection</i> untuk memulai

Item	Fungsi
<i>Duplicate Detection</i>	(mengaktifkan) proses deteksi duplikat <i>review</i> .
<i>Button Verify Spam Candidate</i>	Menuju halaman <i>See Verify Spam Candidate</i> untuk memulai (mengaktifkan) proses verifikasi kandidat <i>review</i> spam
<i>Button Spam Review List</i>	Menuju halaman <i>See Spam Review List</i> untuk melihat daftar <i>review</i> yang tergolong kedalam <i>review</i> spam (terverifikasi).

3.12.2 Antarmuka *Add Review*

The screenshot shows a web form titled "Add Review". The form consists of the following elements:

- Reviewer ID**: A text input field.
- Asin**: A text input field.
- Reviewer Name**: A text input field.
- Review Content**: A large text area for entering the review details.
- Unix Review Time**: A text input field.
- Submit**: A button to submit the form.

Gambar 14 Rancangan Antarmuka *Add Review*

Deskripsi rancangan antarmuka *Add Review* diuraikan pada tabel berikut :

Tabel 6 Deskripsi Rancangan Antarmuka *Add Review*

Item	Fungsi
<i>Textfield Reviewer ID</i>	Input <i>Reviewer ID</i>
<i>Textfield Asin</i>	Input <i>Product ID</i>

Item	Fungsi
<i>Textfield Reviewer Name</i>	Input <i>Reviewer Name</i>
<i>Textfield Content</i>	Input <i>Review Content</i>
<i>Textfield Unix Review Time</i>	Input <i>Unix Review Time</i>

3.12.3 Antarmuka *See Review List*

See Review List

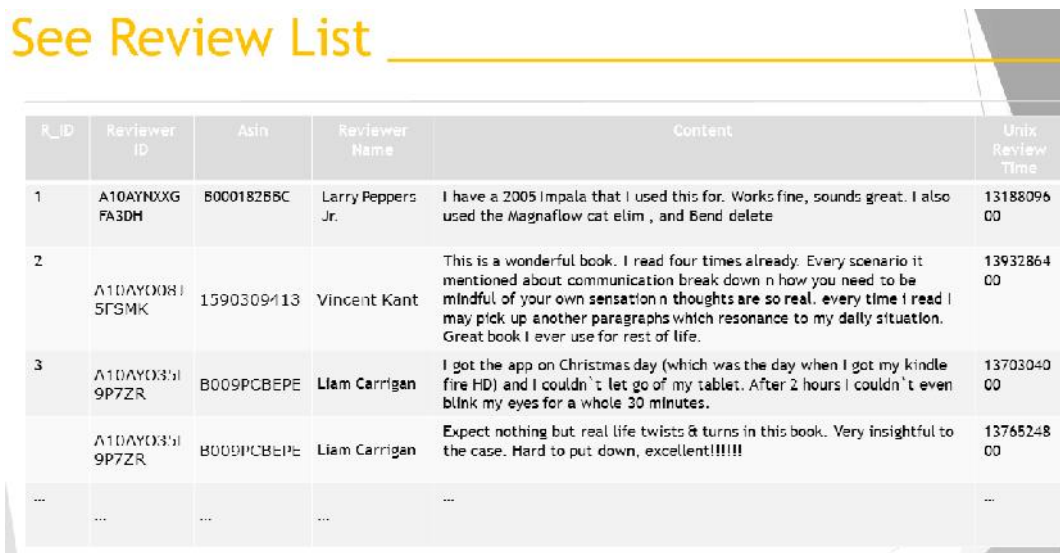

R_ID	Reviewer ID	Asin	Reviewer Name	Content	Unix Review Time
1	A10AYNXXGFA3DH	B000182B5C	Larry Peppers Jr.	I have a 2005 Impala that I used this for. Works fine, sounds great. I also used the Magnaflow cat elim , and Bend delete	1318809600
2	A10AYO08J5FGMK	1590309413	Vincent Kant	This is a wonderful book. I read four times already. Every scenario it mentioned about communication break down n how you need to be mindful of your own sensation n thoughts are so real. every time i read i may pick up another paragraphs which resonance to my dally situation. Great book I ever use for rest of life.	1393286400
3	A10AYO35I9P7ZR	B009PCBEPE	Liam Carrigan	I got the app on Christmas day (which was the day when I got my kindle fire HD) and I couldn't let go of my tablet. After 2 hours I couldn't even blink my eyes for a whole 30 minutes.	1370304000
	A10AYO35I9P7ZR	B009PCBEPE	Liam Carrigan	Expect nothing but real life twists & turns in this book. Very insightful to the case. Hard to put down, excellent!!!!!!	1376524800
...

Gambar 15 Rancangan Antarmuka *See Review List*

Deskripsi rancangan antarmuka *See Review List* diuraikan pada tabel berikut :

Tabel 7 Deskripsi Rancangan Antarmuka *See Review List*

Item	Fungsi
Tabel <i>Review List</i>	Menampilkan daftar <i>review</i> yang sudah disimpan di <i>database</i> aplikasi.

3.12.4 Antarmuka *Start Duplicate Detection*

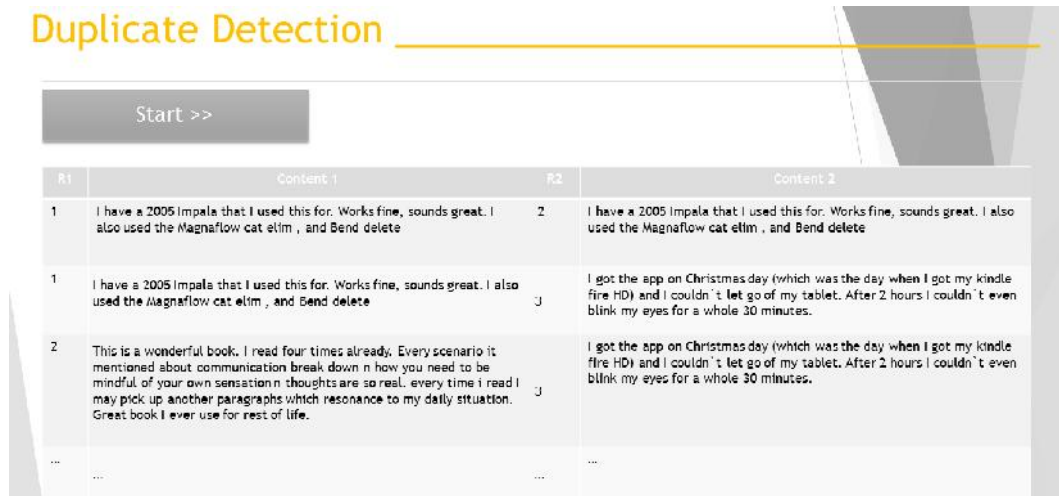

Gambar 16 Rancangan Antarmuka *Start Duplicate Detection*

Deskripsi rancangan antarmuka *Start Duplicate Detection* diuraikan pada tabel berikut :

Tabel 8 Deskripsi Rancangan Antarmuka *Duplicate Detection*

<i>Item</i>	Fungsi
Tombol <i>Start</i>	Mengaktifkan Deteksi Duplikat (fungsi hitung similaritas).
Tabel Pasangan <i>Review</i>	Menampilkan <i>Review</i> yang akan dibandingkan.

3.12.5 Antarmuka *See Spam Candidate*



Gambar 17 Rancangan Antarmuka *See Spam Candidate*

Deskripsi rancangan antarmuka *See Spam Candidate* diuraikan pada tabel berikut:

Tabel 9 Deskripsi Rancangan Antarmuka *See Spam Candidate*

<i>Item</i>	Fungsi
Tabel Kandidat <i>review</i> spam	Menampilkan <i>Review</i> yang dianggap sebagai spam.

3.12.6 Antarmuka *Verify Spam Candidate*

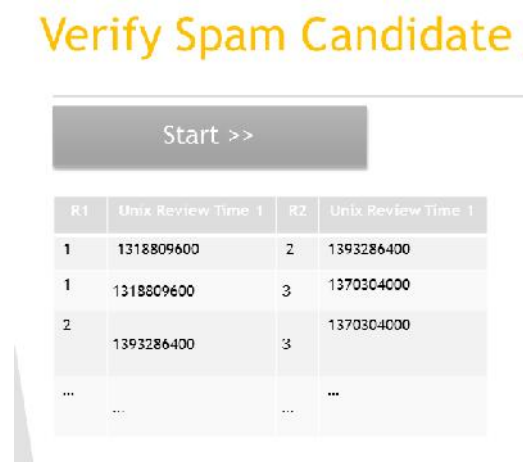

Gambar 18 Rancangan Antarmuka *See Review List*

Deskripsi rancangan antarmuka *Verify Spam Candidate* diuraikan pada tabel berikut :

Tabel 10 Deskripsi Rancangan Antarmuka *Verify Spam Candidate*

<i>Item</i>	Fungsi
Tombol <i>Start</i>	Mengaktifkan Proses verifikasi kandidat spam
Tabel Pasangan <i>Unix Review Time</i>	Menampilkan <i>Unix Review Time</i> yang akan dibandingkan.

3.12.7 Antarmuka *See Spam Review List (Verified)*

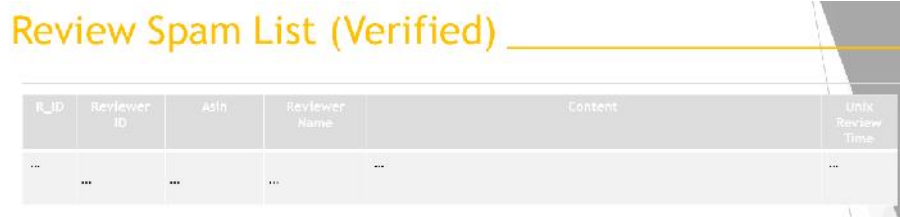

Gambar 19 Rancangan Antarmuka *See Spam Review List*

Deskripsi rancangan antarmuka *See Spam ReviewList* diuraikan pada tabel berikut:

Tabel 11 Deskripsi Rancangan Antarmuka *See Spam Review List*

Item	Fungsi
<i>Tabel Review Spam</i>	Menampilkan <i>Review</i> yang tergolong <i>review spam tipe 1</i>

BAB IV

HASIL DAN PEMBAHASAN

4.1 Implementasi

4.1.1 Implementasi Kelas

Berdasarkan perancangan yang telah dilakukan, maka hasil implementasi kelas dan antarmuka yang dibuat secara rinci dapat dilihat pada tabel berikut :

Tabel 12 *Implementasi Kelas*

No	Nama Kelas	Nama File Fisik
1	<i>Stopword</i>) <i>StopwordTool.cs</i>
2	<i>Similarity</i>) <i>similarity.cs</i>
3	<i>Homepage</i>) <i>Default.aspx</i>) <i>Default.aspx.cs</i>) <i>Default.aspx.designer.cs</i>
4	<i>VerifyCandidate</i>) <i>verify_spam_candidate.aspx.</i>) <i>verify_spam_candidate.aspx.cs</i>) <i>verify_spam_candidate.designer.cs</i>
5	<i>ReviewList</i>) <i>see_review_list.aspx</i>) <i>see_review_list.aspx.cs</i>) <i>see_review_list.aspx.designer.cs</i>
6	<i>InsertReviewForm</i>) <i>insert_review_dataset.aspx</i>) <i>insert_review_dataset.aspx.cs</i>) <i>insert_review_dataset.aspx.designer.cs</i>
7	<i>ResultPage</i>) <i>verified_spam_review_list.aspx</i>) <i>verified_spam_review_list.aspx.cs</i>) <i>verified_spam_review_list.aspx.designer.cs</i>
8	<i>SpamList</i>) <i>see_spam_review.aspx</i>) <i>see_spam_review.aspx</i>

No	Nama Kelas	Nama File Fisik
) <i>see_spam_review.aspx.designer.cs</i>
9	<i>FormInputDataset</i>) <i>FormInputDataset.aspx</i>) <i>FormInputDataset.aspx.cs</i>) <i>FormInputDataset.aspx.aspx.cs</i>

4.1.2 Implementasi Antarmuka

4.1.2.1 Implementasi Antarmuka *Homepage*

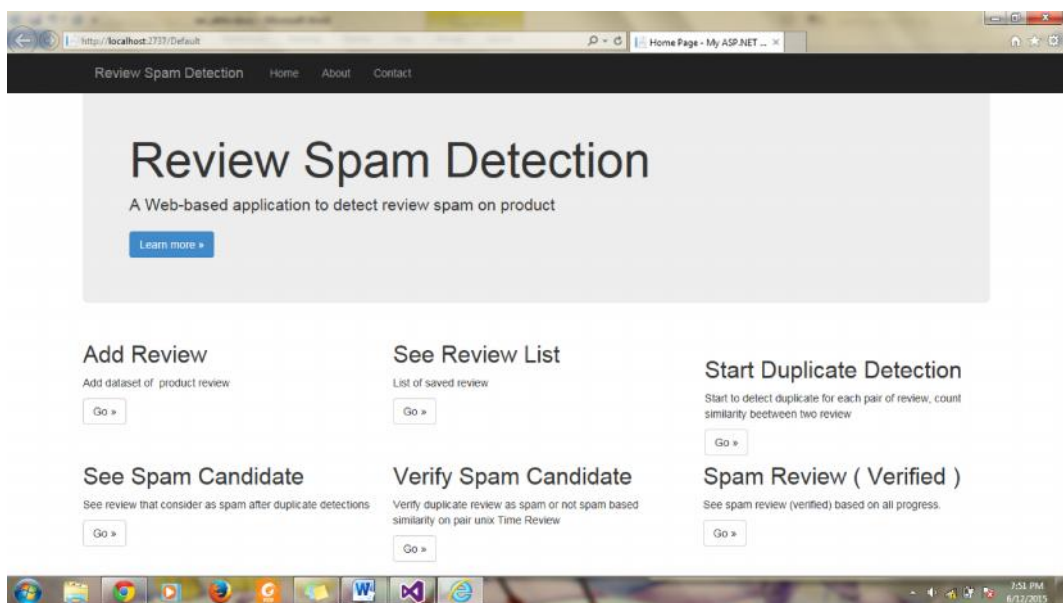

Gambar 20 Implementasi Antarmuka *Homepage*

Deskripsi implementasi antarmuka *Homepage* diuraikan pada tabel berikut :

Tabel 13 Deskripsi Implementasi Antarmuka *Homepage*

Item	Fungsi
Tombol <i>Go» Add Review</i>	Menuju halaman untuk menambahkan <i>dataset review</i>
Tombol <i>Go» See Review List</i>	Menuju halaman untuk melihat daftar <i>review</i>
Tombol <i>Go» Start Duplicate</i>	Menuju halaman untuk memulai deteksi

<i>Item</i>	Fungsi
<i>Detection</i>	<i>review</i> duplikat dan mendekati duplikat
Tombol <i>Go» Verify Spam Candidate</i>	Menuju halaman untuk memulai verifikasi kandidat spam
Tombol <i>Go» Spam Review (Verified)</i>	Menuju halaman untuk melihat daftar <i>review</i> yang tergolong spam tipe 1.
<i>Link Home (right - navigation bar)</i>	Menuju <i>Homepage</i>
<i>Link About (right - navigation bar)</i>	Menuju halaman Tentang Pengembang Aplikasi (Antarmuka Tambahan)
<i>Link Contact (right - navigation bar)</i>	Menuju halaman Kontak Pengembang Aplikasi (Antarmuka Tambahan)
Tombol <i>Go»See Spam Candidate</i>	Melihat daftar kandidat spam

4.1.2.2 Implementasi Antarmuka *Add Review*

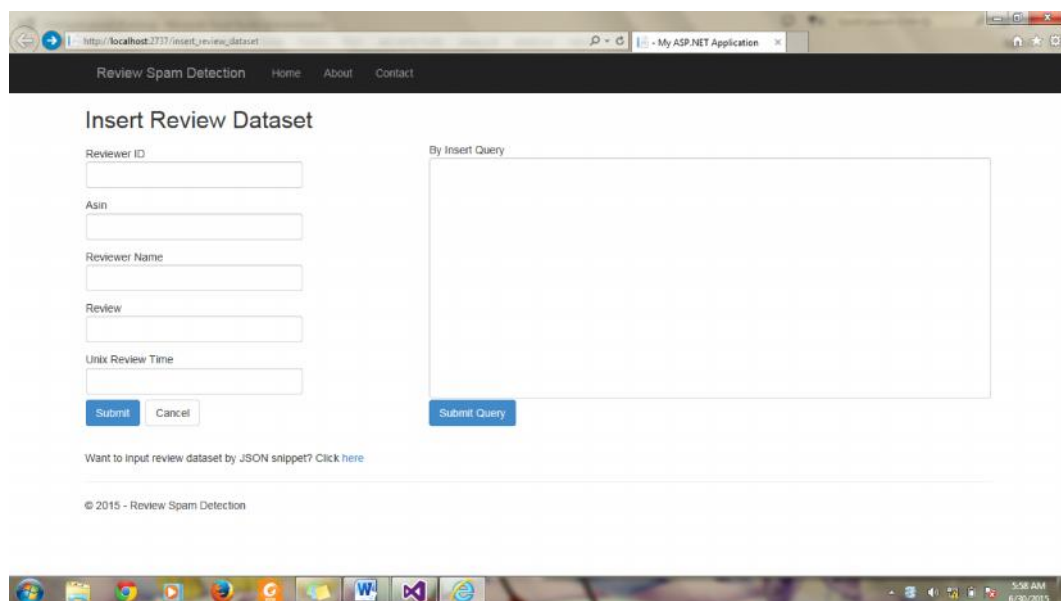

Gambar 21 Implementasi Antarmuka *Add Review*

Deskripsi implementasi antarmuka *Add Review* diuraikan pada tabel berikut :

Tabel 14 Deskripsi Implementasi Antarmuka Add Review

Item	Fungsi
<i>Textbox Reviewer ID</i>	Input ID <i>reviewer</i>
<i>Textbox Asin</i>	Input ID Produk
<i>Textbox Reviewer Name</i>	Input Nama <i>reviewer</i>
<i>Textbox Review</i>	Input <i>Review</i> (isi)
<i>Textbox Unix Review Time</i>	Input waktu unik <i>review</i>
<i>Button Submit</i>	Untuk menyimpan data <i>review</i> yang diinput
<i>Textbox By Insert Query</i>	Input data <i>review</i> berupa <i>query insert</i> baik satu atau lebih dari satu baris (<i>multiline</i>)
<i>Button Submit Query</i>	Eksekusi <i>Query Insert</i> yang diinput pada <i>Textbox By Insert Query</i>
<i>Linkbutton here</i>	Menuju Halaman input <i>review</i> dengan format JSON.

Selain itu juga ditambahkan antarmuka untuk input *dataset* dengan format JSON yang telah melalui proses *preprocessing review* seperti yang dijelaskan pada 3.1.3.1 hingga point ke-2. Antarmuka ini ditambahkan diluar perancangan pada bab 3 karena dinilai lebih memudahkan dalam input *dataset review* produk di Amazon.com, yang berupa teks dalam format JSON.

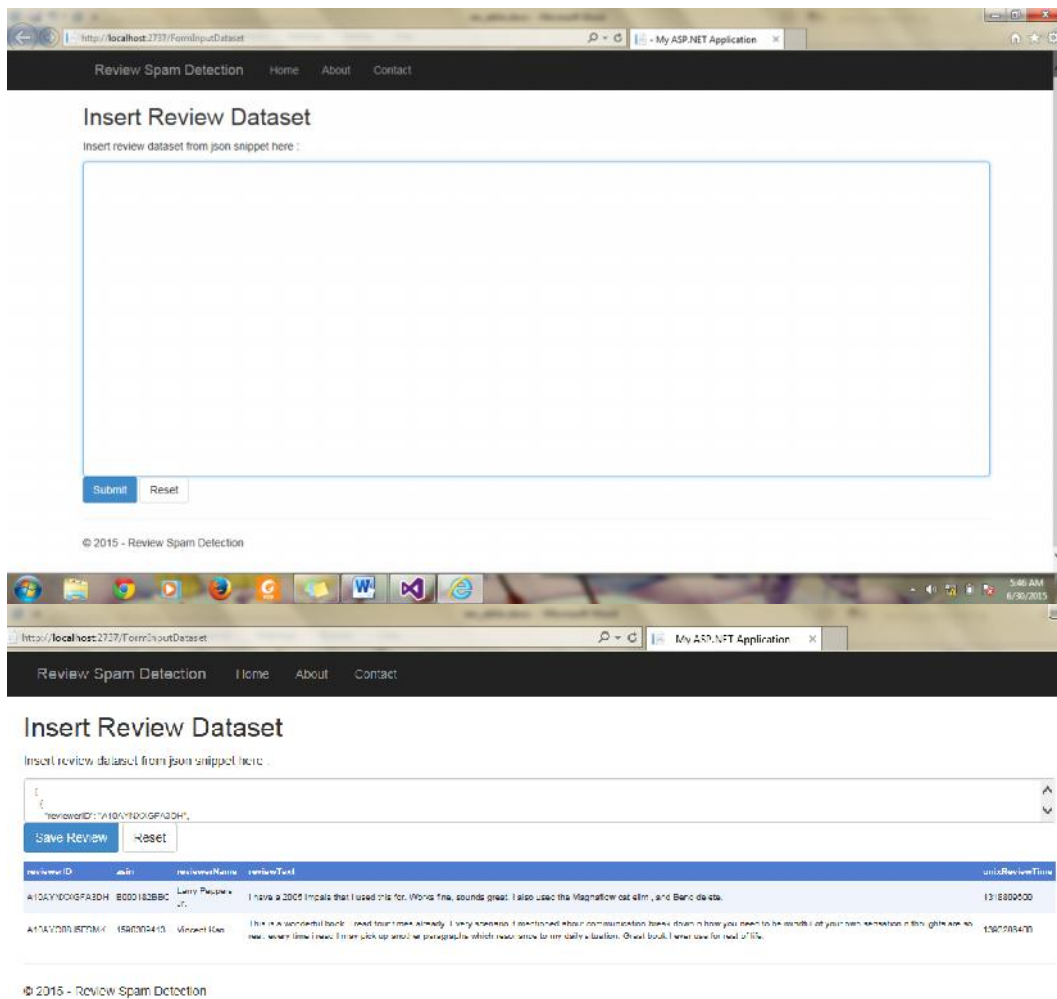

Gambar 22 Antarmuka tambahan *Insert Review Dataset*

Deskripsi implementasi antarmuka tambahan *Insert Review Dataset* diuraikan pada tabel berikut :

Tabel 15 Deskripsi Implementasi Antarmuka tambahan *Insert Review Dataset*

Item	Fungsi
<i>Button Submit</i>	Memasukkan potongan <i>dataset</i> dalam format JSON yang kemudian akan diubah menjadi bentuk tabel.
<i>Button Reset</i>	Mengosongkan <i>Textbox Review</i>
<i>Textbox Review</i>	Input potongan <i>dataset</i> dalam format JSON

Item	Fungsi
Tabel <i>Review</i>	Menampilkan <i>review</i> dalam bentuk tabel, hasil input sebelumnya
Button <i>Save Review</i>	Menyimpan <i>review</i> ke dalam <i>database</i>

4.1.2.3 Implementasi Antarmuka *See Review List*

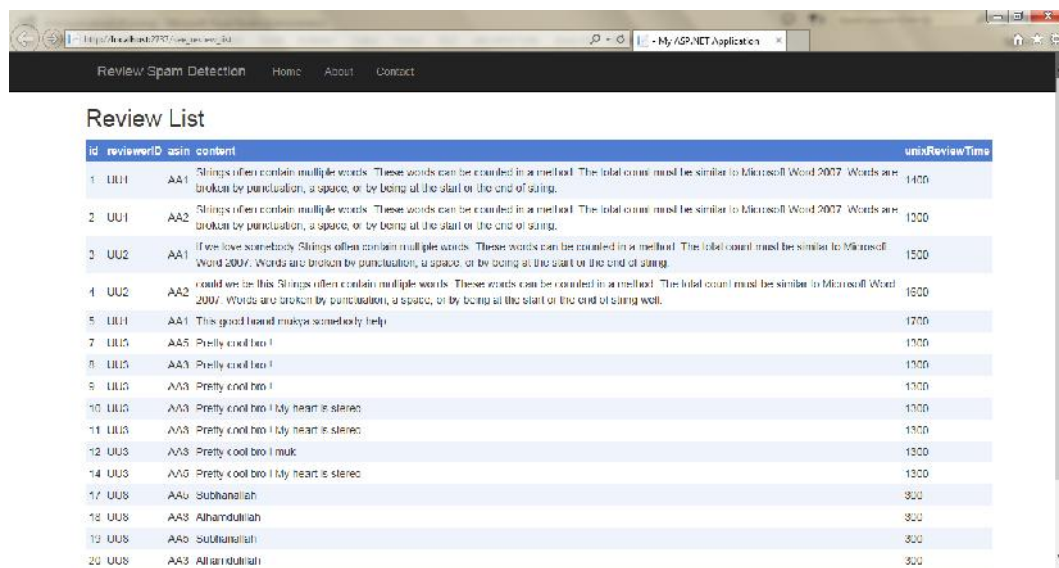

Gambar 23 Implementasi Antarmuka *See Review List*

Deskripsi implementasi antarmuka *See Review List* diuraikan pada tabel berikut :

Tabel 16 Deskripsi Implementasi Antarmuka *See Review List*

Item	Fungsi
Tabel <i>Review</i>	Menampilkan <i>review</i> yang sudah disimpan

4.1.2.4 Implementasi Antarmuka *Start Duplicate Detection*

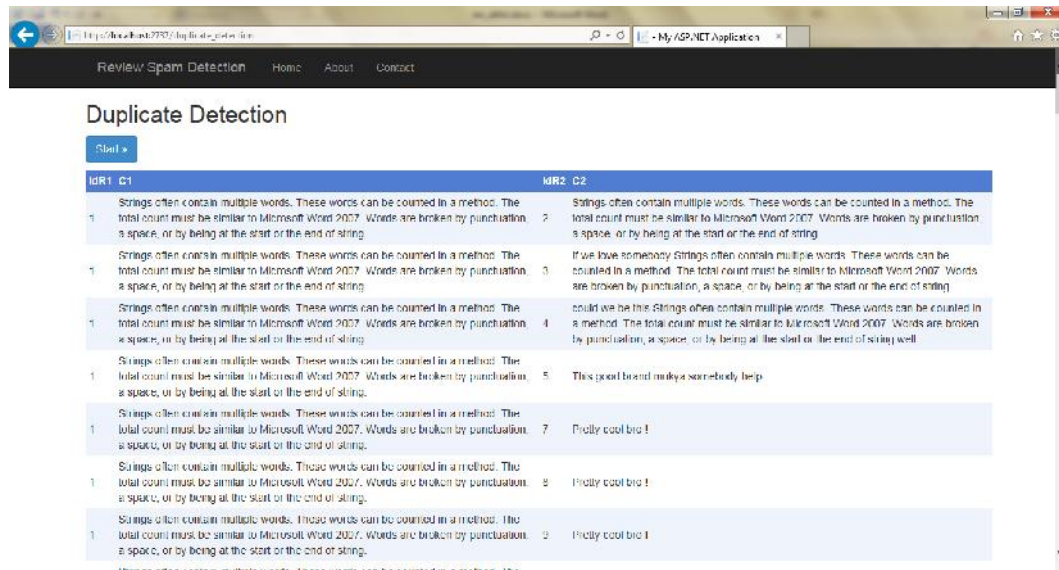

Gambar 24 Implementasi Antarmuka *Start Duplicate Detection*

Deskripsi implementasi antarmuka *Start Duplicate Detection* diuraikan pada tabel berikut :

Tabel 17 Deskripsi Implementasi Antarmuka *Start Duplicate Detection*

Item	Fungsi
Tabel Pasangan <i>Review</i>	Menampilkan pasangan <i>review</i> yang akan dideteksi duplikat atau mendekati duplikat
Button Start»	Memulai kalkulasi similaritas antar pasangan <i>review</i>

4.1.2.5 Implementasi Antarmuka *See Spam Candidate*

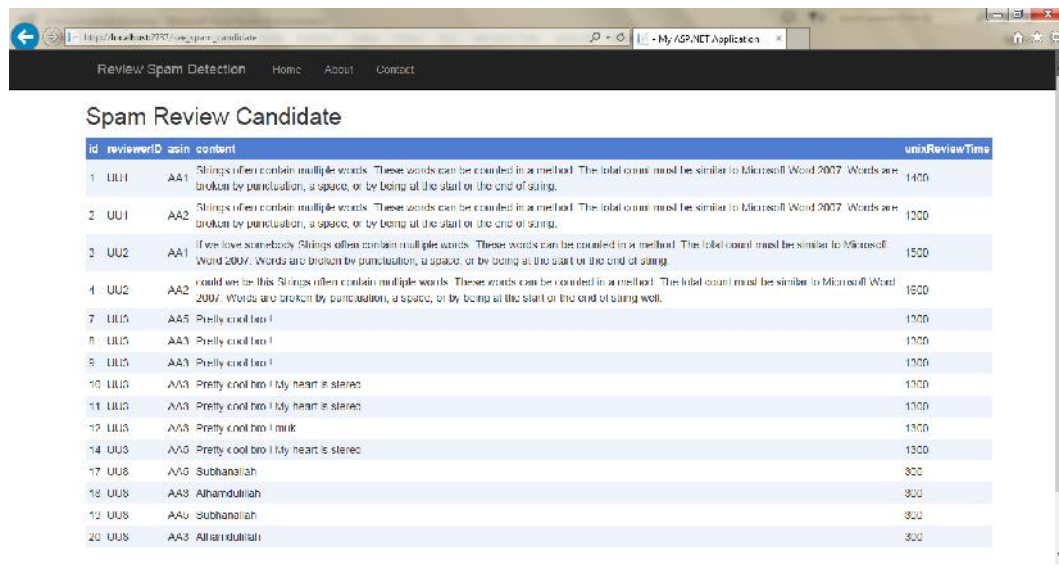

Gambar 25 Implementasi Antarmuka *See Spam Candidate*

Deskripsi implementasi antarmuka *See Spam Candidate* diuraikan pada tabel berikut :

Tabel 18 Deskripsi Implementasi Antarmuka *See Spam Candidate*

Item	Fungsi
Tabel <i>Spam Candidate</i>	Menampilkan kandidat <i>review</i> spam

4.1.2.6 Implementasi Antarmuka *Verify Spam Candidate*

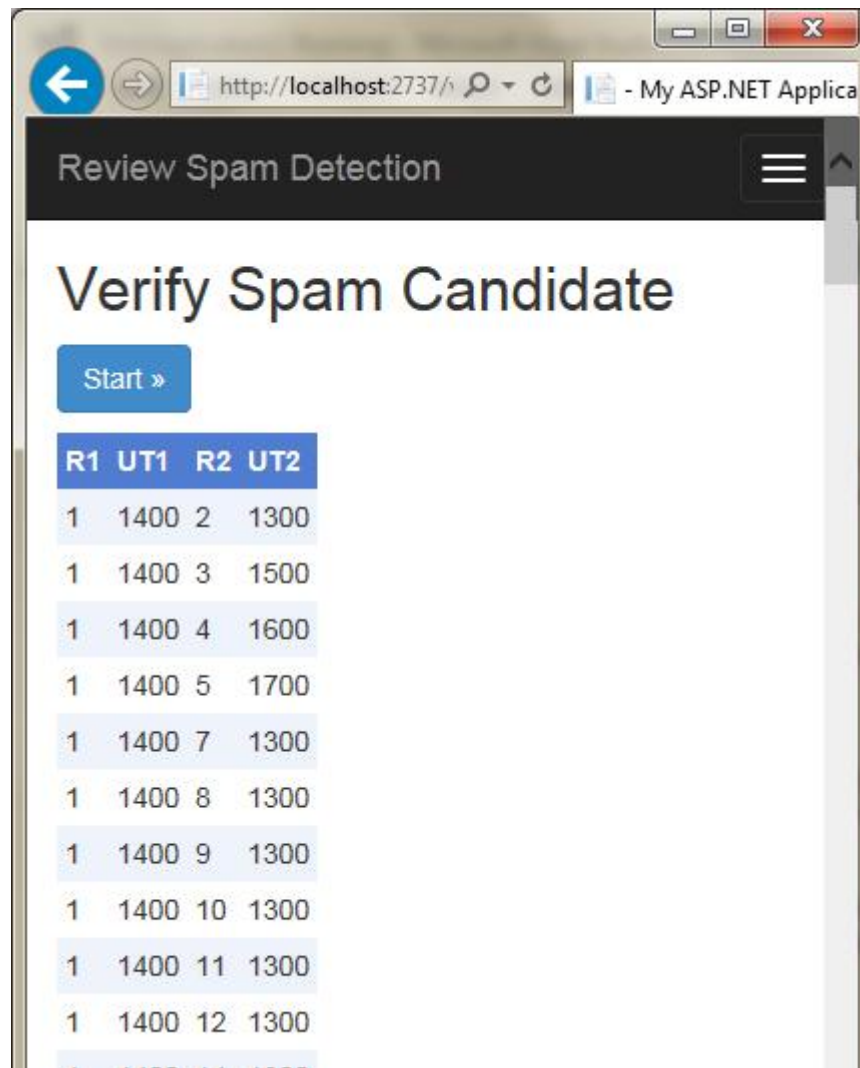

Gambar 26 Implementasi Antarmuka *Verify Spam Candidate*

Deskripsi rancangan antarmuka *Verify Spam Candidate* diuraikan pada tabel berikut :

Tabel 19 Deskripsi Implementasi Antarmuka *Verify Spam Candidate*

Item	Fungsi
Tabel Pasangan <i>Unix Review Time</i>	Menampilkan dua <i>Unix Review Time</i> yang akan dibandingkan sama tidaknya

4.1.2.7 Implementasi Antarmuka *See Spam Review List (Verified)*

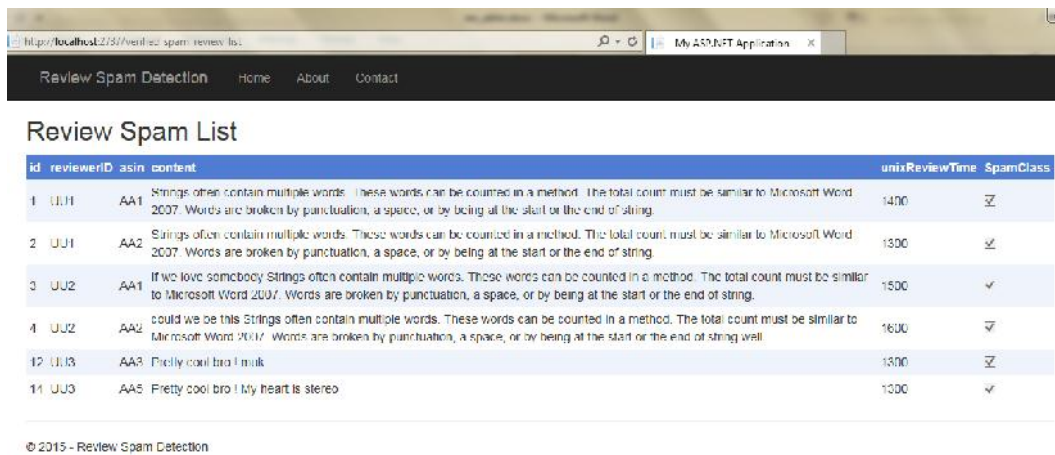

Gambar 27 Implementasi Antarmuka *See Review List (Verified)*

Deskripsi rancangan antarmuka *See Review List (verified)* diuraikan pada tabel berikut :

Tabel 20 Deskripsi Implementasi Antarmuka *See Review List (Verified)*

Item	Fungsi
Tabel <i>Review Spam List</i>	Menampilkan <i>review</i> spam terverifikasi

4.1.3 Implementasi *Source Code*

4.1.3.1 *Source Code* mengolah teks JSON untuk penyiapan *review*

Source code mengolah teks JSON untuk penyiapan *review* dapat dilihat pada tabel berikut :

Tabel 21 *Source Code* mengolah Teks JSON untuk penyiapan *review*

<i>Source Code</i> mengolah teks JSON untuk penyiapan <i>review</i>
<pre>using System; using System.Collections.Generic; using System.Linq; using System.Web; using System.Web.UI; using System.Web.UI.WebControls; using System.Data; using System.IO; using Newtonsoft.Json;</pre>

Source Code mengolah teks JSON untuk penyiapan review

```
using Newtonsoft.Json.Linq;
using System.Web.Configuration;
using System.Data.SqlClient;

namespace DeteksiUlasanSpam
{
    public partial class WebForm4 : System.Web.UI.Page
    {
        SqlConnection con;
        SqlCommand cmd, cmd2, cmd3, cmd4, cmd5 ;
        //SqlDataReader dr;
        private string s;
        protected void Page_Load(object sender, EventArgs e)
        {

        }

        protected void Button2_Click(object sender, EventArgs e)
        {
            int totalreview = GridView1.Rows.Count;
            int i = 0;

            s =
WebConfigurationManager.ConnectionStrings["DOS2ConnectionString"].Connection
nString;
            con = new SqlConnection(s);
            try
            {
                con.Open();
            }
            catch {
                Response.Write("Please check the database connection !!");
            }

            for (i = 0; i < totalreview; i++) {
                String reviewerID = GridView1.Rows[i].Cells[0].Text;
                String asin = GridView1.Rows[i].Cells[1].Text;
                String reviewerName = GridView1.Rows[i].Cells[2].Text;
                String reviewText = GridView1.Rows[i].Cells[3].Text;
                int unixReviewTime =
Convert.ToInt32(GridView1.Rows[i].Cells[4].Text);

                //cek id reviewer
                string checkreviewerID = "Select count(ReviewerID) From
Reviewer where reviewerID = @reviewerID;";
                cmd = new SqlCommand(checkreviewerID, con);
                cmd.Parameters.Add("@reviewerID", SqlDbType.VarChar,
25).Value = reviewerID;
                int exist = (int) cmd.ExecuteScalar();

                //masukkan reviewer
                if (exist == 0)
                {
                    string insertReviewer = "INSERT INTO reviewer
```

Source Code mengolah teks JSON untuk penyiapan *review*

```
values(@reviewerID,@reviewerName);" ;
        cmd2 = new SqlCommand(insertReviewer, con);
        cmd2.Parameters.Add("@reviewerID",
SqlDbType.VarChar, 25).Value = reviewerID;
        cmd2.Parameters.Add("@reviewerName",
SqlDbType.VarChar, 25).Value = reviewerName;
        cmd2.ExecuteNonQuery();
    }

    //cek product berdasarkan ID
    string checkAsin = "Select count(asin) From Product
where asin = @asin;";
    cmd3 = new SqlCommand(checkAsin, con);
    cmd3.Parameters.Add("@asin", SqlDbType.VarChar,
25).Value = asin;
    int exist2 = (int)cmd3.ExecuteScalar();

    //masukkan product
    if (exist2 == 0)
    {
        string insertProduct = "INSERT INTO Product
values(@asin)";
        cmd4 = new SqlCommand(insertProduct, con);
        cmd4.Parameters.Add("@asin", SqlDbType.VarChar,
25).Value = asin;
        cmd4.ExecuteNonQuery();
    }

    //masukkan komentar
    string insertReview = "INSERT INTO [Review]
([reviewerID], [asin], [content], [unixReviewTime]) VALUES (@reviewerID,
@asin, @content, @unixReviewTime)";
    cmd5 = new SqlCommand(insertReview, con);
    cmd5.Parameters.Add("@reviewerID",
SqlDbType.VarChar, 25).Value = reviewerID;
    cmd5.Parameters.Add("@asin", SqlDbType.VarChar,
25).Value = asin;
    cmd5.Parameters.Add("@content",
SqlDbType.Text).Value = reviewText;
    cmd5.Parameters.Add("@unixReviewTime",
SqlDbType.Int).Value = unixReviewTime;
    cmd5.ExecuteNonQuery();
}
    string script = "alert('Review dataset saved succesfully
!!)';";
    ClientScript.RegisterClientScriptBlock(this.GetType(), "Alert",
script, true);
    Button2.Visible = false;
}

protected void Button1_Click(object sender, EventArgs e)
{
    GridView1.Visible = true;
}
```

Source Code mengolah teks JSON untuk penyiapan review

```
        Button3.Enabled = true;
        string JsonString = TextBox1.Text;
        try
        {
            var obj = JToken.Parse(JsonString);

            var keepers = new HashSet<string>(new[]
{"reviewerID", "asin", "reviewerName", "reviewText", "unixReviewTime", });
            foreach (var property in obj.Children().SelectMany(o =>
o.OfType<JProperty>()).Where(p => !keepers.Contains(p.Name)).ToList())
            {
                property.Remove();
            }

            var dt = obj.ToObject<DataTable>();
            GridView1.DataSource = dt;
            GridView1.DataBind();
        }
        catch
        {
            string script = "alert('Please check again your json
snippet / Wrong format !!');";
            ClientScript.RegisterClientScriptBlock(this.GetType(),
"Alert", script, true);
        }

        TextBox1.Height = 50;
        GridView1.Focus();
        Button1.Visible = (false);
        Button2.Visible = true;
    }

    protected void TextBox1_TextChanged(object sender, EventArgs e)
    {
        TextBox1.Height = 166;
    }

    protected void GridView1_SelectedIndexChanged(object sender,
EventArgs e)
    {
    }

    protected void Button3_Click(object sender, EventArgs e)
    {
        TextBox1.Text = "";
        TextBox1.Height = 166;
        Button1.Visible = true;
        Button2.Visible = false;
        Button3.Enabled = false;
        GridView1.Visible = false;
    }
}
}
```

4.1.3.2 Source Code Penghapusan Stop-word dan Deteksi Duplikat review

Source Code penghapusan stop-word dan deteksi duplikat antar review dapat dilihat pada tabel berikut :

Tabel 22 Source Code Penghapusan Stopword dan Deteksi Duplikat

Source Code Penghapusan stop-word antar review
<pre>using System; using System.Collections.Generic; using System.Linq; using System.Web; using System.Web.UI; using System.Web.UI.WebControls; using System.Data.SqlClient; using System.Data; using System.Web.Configuration; using System.Text.RegularExpressions; using DOS; namespace DeteksiUlasanSpam { public partial class duplicate_detection : System.Web.UI.Page { SqlConnection con; SqlCommand cmd, cmd2; private string s; int totalrow = 0; static double j_coef; Int32 R1, R2; protected void Page_Load(object sender, EventArgs e) { Label15.Visible = false; } protected void Button1_Click(object sender, EventArgs e) { DataView dv = (DataView)SqlDataSource3.Select(DataSourceSelectArguments.Empty); DataTable dt = new DataTable(); dt = dv.ToTable(); int tr = dt.Rows.Count; Label15.Visible = true; s = WebConfigurationManager.ConnectionStrings["DOS2ConnectionString"].Connection nString; con = new SqlConnection(s); con.Open(); for (int i = 0; i < tr; i++) {</pre>

Source Code Penghapusan stop-word antar review

```
R1 = Convert.ToInt32(dt.Rows[i][0]);
String Review1 = dt.Rows[i][1].ToString();
R2 = Convert.ToInt32(dt.Rows[i][2]);
String Review2 = dt.Rows[i][3].ToString();

// menghitung skor similaritas dengan parameter review
yang dihapus stopwords-nya
j_coef =
similarity.JaccardSimilarity(StopwordTool.RemoveStopwords(Review1),
StopwordTool.RemoveStopwords(Review2));

//Update nilai result
cmd2 = new SqlCommand("UPDATE Result SET
sim_score=@sim_score WHERE R1=@R1 AND R2=@R2", con);
//cmd = new SqlCommand("INSERT INTO
Result(R1,R2,sim_score) VALUES (@R1,@R2,@sim_score)", con);
cmd2.Parameters.Add("@R1", SqlDbType.Int).Value = R1;
cmd2.Parameters.Add("@R2", SqlDbType.Int).Value = R2;
cmd2.Parameters.Add("@sim_score",
SqlDbType.Float).Value = j_coef;

cmd2.ExecuteNonQuery();

}

//set kelas spam
string updateclassspam = "UPDATE Review SET SpamClass=1
WHERE ID IN((SELECT R1 FROM Result WHERE sim_score>=0.9) UNION (SELECT R2
FROM Result WHERE sim_score>=0.9))";
cmd = new SqlCommand(updateclassspam, con);
cmd.ExecuteNonQuery();

Button1.Visible = false;
GridView1.Visible = false;
Label6.Text = "Finish";
Response.AddHeader("REFRESH", "3;duplicate_detection.aspx");

}

}
```

4.1.3.3 Source Code Verifikasi

Source Code penghapusan *stop-word* dan deteksi ulasan duplikat antar review dapat dilihat pada tabel berikut :

Tabel 23 Source Code untuk verifikasi review

Source Code verifikasi review
<pre>using System; using System.Collections.Generic; using System.Linq; using System.Web; using System.Web.UI; using System.Web.UI.WebControls; using System.Data.SqlClient; using System.Data; using System.Web.Configuration; namespace DeteksiUlasanSpam { public partial class verify_spam_candidate : System.Web.UI.Page { SqlConnection con; SqlCommand cmd,cmd2,cmd3,cmd4; private string s; int totalrow = 0; Int32 R1,UT1,R2,UT2; string sim_score; protected void Page_Load(object sender, EventArgs e) { } protected void Button1_Click(object sender, EventArgs e) { Label1.Text = ""; try { s = WebConfigurationManager.ConnectionStrings["DOS2ConnectionString"].Connectio nString; con = new SqlConnection(s); con.Open(); //cek unixtime similarity String update_sim_unixrev = "update Result set sim_unixReviewTime=1 where((select unixReviewTime from Review where id=Result.R1)=(select unixreviewtime from viewReview where viewReview.Expr1=result.R2))"; cmd = new SqlCommand(update_sim_unixrev, con); cmd.ExecuteNonQuery();</pre>

"save" diklik aplikasi menampilkan *dataset* ulasan dalam bentuk tabel *grid*, beberapa atribut yang tidak digunakan tidak ditampilkan, dan yang diperlukan ditampilkan. Konversi teks JSON menjadi tabel ini dilakukan dengan menggunakan pustaka JSON.NET. Setelah dikonfirmasi maka nilai pada baris ke-n dan kolom ke-n akan menjadi parameter untuk melakukan *query insert* ke dalam *database*.

Dalam implementasi proses ini sebanyak 153 sampel *review* dimasukkan ke dalam *database* yaitu ke dalam tabel *Review*. Sebelum masuk ke dalam tabel *review*, informasi *ReviewerID* dan *ReviewerName* dimasukkan ke dalam tabel *Reviewer* dan *asin* (ID produk) dimasukkan ke dalam tabel *Product*. Hal ini dilakukan karena rancangan *database* pada aplikasi ini pada tabel *Review* ada *constrain foreign key* untuk informasi *reviewer* dan *product*. Untuk otomatisasi sebuah trigger *insert select* pada tabel *review* dan *view*-nya. Sehingga kombinasi silang masuk ke dalam tabel *Result*.

4.1.4.2 Penghapusan Stopword dan Deteksi Duplikat

Penghapusan *stopword* dilakukan dengan menggunakan *StopwordTool*. Penghapusan *stopword* dan deteksi duplikat pada *review* diimplementasikan pada halaman deteksi duplikat yang dapat dituju dengan klik "Start Duplicate Detection" pada *Homepage*. Setiap *review* dihapus *stopword* yang ada di dalamnya kemudian *review* yang sudah dihapus *stopword* tersebut dijadikan parameter untuk deteksi duplikat. Untuk pasangan *review* yang akan dideteksi sudah ada pada tabel *result* yang sebelumnya data di dalamnya ada atas trigger yang dipasang pada tabel *Review*.

Fungsi similaritas *Jaccard* digunakan untuk membandingkan dua *review* yang sudah bersih dari *stopword* kemudian hasilnya dimasukkan (*update*) ke dalam *field sim_score* pada tabel *Result*. Setelah semua pasangan *review* dideteksi nilai similaritasnya. Kemudian semua pasangan yang tergolong duplikat ($\text{sim_score} \geq 0.9$) maka pada tabel *Review* di-*update spamClass*-nya menjadi

bernilai 1 (*True*), id pasangan *review* (baik R1 maupun R2) tersebut menjadi referensi untuk *update* pada tabel *Review*.

4.1.4.3 Verifikasi Kandidat Spam

Verifikasi kandidat spam dilakukan dengan mengecek kesamaan nilai pada atribut *review* yaitu *UnixReviewTime*, *Asin*, dan *ReviewerID*, jika sama maka bernilai 1 dan jika tidak bernilai nol. Sehingga setelah nilai kesamaannya didapatkan maka tabel *Result* di-update nilai untuk *field-field* yaitu *sim_UnixReviewTime*, *sim_Asin*, dan *sim_ReviewerID*. Jika seluruhnya sama maka spamClass ulasan dengan ID tersebut di-*update* menjadi 0 yang artinya tidak tergolong spam.

4.2 Pengujian

4.2.1 Tujuan Pengujian

Pengujian ini bertujuan untuk menemukan kesalahan yang mungkin terdapat dalam aplikasi dan mengetahui apakah aplikasi yang dibuat telah sesuai dengan tujuan yang telah ditetapkan sebelumnya.

4.2.2 Strategi Pengujian

Strategi Pengujian aplikasi ini menggunakan metode *Black Box* yaitu pengujian yang berfokus pada kebutuhan Deskripsi Fungsional untuk mengetahui jalannya aplikasi secara lengkap. Kemudian pengujian dilakukan kepada pengguna untuk mengetahui respon pengguna.

4.2.3 Hasil Pengujian

Hasil pengujian Aplikasi Deteksi Review Spam pada *Review* Produk Amazon.com dapat dilihat pada tabel Hasil Pengujian Aplikasi.

Nama Penguji : Diah Shinta Rini

Tanggal Pengujian : 10 Agustus 2015

Jumlah Sampel Data : 153 *review*.

Tabel 24 Hasil Pengujian Aplikasi

No	Use Case	Skenario Uji	Hasil yang Diharapkan	Pengujian	
				Sesuai	Tidak Sesuai
1	Memasukkan <i>Dataset Review</i>	Pengguna memasukkan dataset <i>review</i> kemudian <i>dataset</i> disimpan kedalam <i>database</i>	Data masuk kedalam <i>database</i>	✓	
2	Melihat Daftar <i>Review</i>	Pengguna masuk ke halaman <i>See Review List</i> kemudian sistem menampilkan daftar <i>review</i> yang sudah disimpan	Data yang sudah disimpan ditampilkan berupa tabel	✓	
3	Mengaktifkan Deteksi Duplikasi	Pengguna memilih menu <i>Start Duplicate Detection</i> kemudian masuk ke halaman <i>Start Duplicate Detection</i> , selanjutnya menekan tombol	Sistem menghitung nilai similaritas antar pasangan <i>review</i> , dan membuat kandidat spam.	✓	

No	Use Case	Skenario Uji	Hasil yang Diharapkan	Pengujian	
				Sesuai	Tidak Sesuai
		<i>Start</i> untuk memulai			
4	Melihat Kandidat Spam	Pengguna masuk ke halaman <i>See Review Spam Candidate</i>	Sistem menampilkan kandidat <i>review</i> spam	✓	
5	Mengaktifkan Verifikasi Kandidat Spam	Pengguna masuk ke halaman <i>Verify Spam Candidate</i> kemudian menekan tombol <i>Start</i>	Sistem mengkalkulasi nilai similaritas <i>unix review time, product id, dan reviewer id</i> dan meng- <i>update</i> daftar kandidat spam <i>review</i> , yang duplikat bukan spam.	✓	
6	Melihat <i>Review Spam</i> Terverifikasi	Pengguna masuk ke halaman <i>See Spam Review List (Verified)</i> dan sistem menampilkan daftar <i>review</i> yang tergolong spam tipe 1	Daftar <i>review</i> spam ditampilkan.dalam bentuk tabel	✓	

4.2.4 Review Spam Duplikat yang Terdeteksi

Setelah semua proses deteksi dilakukan didapatkan beberapa *review* spam duplikat sebelum verifikasi dan setelah verifikasi yang ditampilkan pada tabel berikut :

Tabel 25 *Review Spam duplikat sebelum Verifikasi*

id	reviewer ID	asin	content	unix Review Time
8	A1MUV HT8BON L5K	0634029 347	I bought this DVD and I'm returning it. The description and editorial review are misleading. This is NOT a Clapton video. Certainly some clips from Clapton, but generally this is a "how to" video. Same applies to Clapton The Early Years!	112933 4400
12	A1MUV HT8BON L5K	0634029 355	I bought this DVD and I'm returning it. The description and editorial review are misleading. This is NOT a Clapton video. Certainly some clips from Clapton, but generally this is a "how to" video. Also applies to Clapton The Solo Years.	112933 4400
42	A153V2 QD4BJT 1Z	0739003 755	We are very happy with this series. My son has special needs and benefits from music therapy weekly. This series teaches about musical concepts with a story book format. We also bought the companion CD and stuffed animals.	136408 3200
43	A153V2 QD4BJT 1Z	0739003 755	We are very happy with this series. My son has special needs and benefits from music therapy weekly. This series teaches about musical concepts with a story book format. We also bought the companion CD and stuffed animals.	136408 3200
156	A000152 8BGUBO EVR6T5 U	B0055Q 2VNI	Great. Fast, silent, big drive. I would recommend to anyone. For the price its a great buy and internally its a good drive.	136287 3600
157	A000152 8BGUBO EVR6T5 U	B0055Q 2VS8	Great. Fast, silent, big drive. I would recommend to anyone. For the price its a great buy and internally its a good drive.	136287 3600
158	A000152	B0058U	Great!	140434

id	reviewer ID	asin	content	unix Review Time
	8BGUBO EVR6T5 U	UR6E		5600
159	A000152 8BGUBO EVR6T5 U	B005HT H78W	Great!	140434 5600
160	A000152 8BGUBO EVR6T5 U	B005P WV1O W	Great!	140434 5600

Tabel 26 *Review Spam Duplikat setelah Verifikasi*

id	reviewer ID	asin	content	unix Review Time
8	A1MUV HT8BON L5K	0634029 347	I bought this DVD and I'm returning it. The description and editorial review are misleading. This is NOT a Clapton video. Certainly some clips from Clapton, but generally this is a "how to" video. Same applies to Clapton The Early Years!	1129334 400
12	A1MUV HT8BON L5K	0634029 355	I bought this DVD and I'm returning it. The description and editorial review are misleading. This is NOT a Clapton video. Certainly some clips from Clapton, but generally this is a "how to" video. Also applies to Clapton The Solo Years.	1129334 400

id	reviewer ID	asin	content	unix Review Time
156	A000152 8BGUB OEVR6T 5U	B0055Q 2VNI	Great. Fast, silent, big drive. I would recommend to anyone. For the price its a great buy and internally its a good drive.	1362873 600
157	A000152 8BGUB OEVR6T 5U	B0055Q 2VS8	Great. Fast, silent, big drive. I would recommend to anyone. For the price its a great buy and internally its a good drive.	1362873 600
158	A000152 8BGUB OEVR6T 5U	B0058U UR6E	Great!	1404345 600
159	A000152 8BGUB OEVR6T 5U	B005HT H78W	Great!	1404345 600
160	A000152 8BGUB OEVR6T 5U	B005P WV1O W	Great!	1404345 600

Total Review Spam Duplikat :

Sebelum = 8 *review*

Sesudah = 7 *review*

BAB V

KESIMPULAN DAN SARAN

5.1 Kesimpulan

Berdasarkan tahapan analisis, perancangan dan implementasi pada Aplikasi Deteksi *Review* Spam pada *Review* Produk Amazon.com ini, maka dapat disimpulkan bahwa :

1. Aplikasi dapat dirancang menggunakan pendekatan *unified modeling language*.
2. Aplikasi dapat mendeteksi suatu *review* merupakan spam atau tidak menggunakan metode deteksi duplikat dengan pendekatan *review-centric*.

5.2 Saran

Dalam pembuatan aplikasi ini, disadari masih terdapat banyak kekurangan dan kelemahan, oleh karena itu untuk pengembangan selanjutnya disarankan :

1. Aplikasi selanjutnya dapat digunakan secara *real-time*, atau dapat berupa *plug-in* pada *website*.
2. Pendekteksian dilakukan dengan metode lebih lanjut seperti dengan klasifikasi dengan fitur-fitur yang ada pada *review*.
3. Melakukan uji keakuratan aplikasi menggunakan data publik berupa data *training* pada penelitian lebih lanjut

DAFTAR PUSTAKA

- DotNetPerls. (t.thn). *Stopword Dictionary*. Dipetik 6 Juni 2015, dari <http://www.dotnetperls.com/stopword-dictionary>
- G Harris, Christopher. (2012). *Detecting Deceptive Opinion Spam Using Human Computation*. AAAI Technical Report WS-12-08, (hal 87-93).
- Jindal, Nitin, Bing Liu.(2008). *Opinion Spam and Analysis*. Department of Computer Science University of Illinois at Chicago 851 South Morgan Street, Chicago, IL 60607-7053.
- Jindal, Nitin, Bing Liu(2007). *Review Spam Detection*. Proceedings of Compression and Complexity.(hal. 1189-1190)
- Liu, Bing and Lei Zhang. *A Survey of Opinion Mining and Sentiment Analysis* . Proceeding of the 14th International Conference on Intelligence Text Processing and Computational Linguistic.
- Liu, B. (2012). *Sentiment Analysis and Opinion Mining*. Morgan & Claypool.
- McAuley, J. (t.thn.). *Amazon Review Data*. Dipetik Mei 1, 2015, dari Amazon product data: <http://jmcauley.ucsd.edu/data/amazon/>
- Wibisono, E. (2008, Juli 23). *Stop words untuk Bahasa Indonesia*. Dipetik Juli 5, 2015, dari Blog Eko Wibisono: <https://yudiwbs.wordpress.com/2008/07/23/stop-words-untuk-bahasa-indonesia/>
- Wikipedia. (2013, November 14). *Amazon Standard Identification Number*. Dipetik Juni 11, 2015, dari http://id.wikipedia.org/wiki/Amazon_Standard_Identification_Number

LAMPIRAN

Sampel Data Review Produk Amazon.com

Tabel 27 Sampel Data Review Produk Amazon

id	reviewerID	asin	Content	unix Review Time
1	A1YS9MD ZP93857	00064 28320	The portfolio is fine except for the fact that the last movement of sonata #6 is missing. What should one expect?	139449 6000
2	A3TS466Q BAWB9D	00140 72149	If you are a serious violin student on a budget, this edition has it all: Piano accompaniment, low price, urtext solo parts, and annotations by Maestro David Oistrakh where Bach's penmanship is hard to decipher. Additions (in dashes) are easily distinguishable from the original bowings. This is a delightful concerto that all intermediate level violinists should perform with a violin buddy. Get your copy, today, along with "The Green Violin; Theory, Ear Training, and Musicianship for Violinists" book to prepare for this concerto and for more advanced playing!	137047 6800
3	A3BUDYI TWUSIS7	00412 91905	This is an excellent edition and perfectly true to the orchestral version! It makes playing Vivaldi a joy! I use this for a wedding and was totally satisfied with the accuracy!	138170 8800
4	A19K10Z0 D2NTZK	00419 13574	Perfect for someone who is an opera fan or a working musician. Aida: Aida (sometimes spelled Ada, pronounced ah-EE-dah, is an Arabic female name meaning "visitor" or "returning") is an opera in four acts by Giuseppe Verdi to an Italian libretto by Antonio Ghislanzoni, based on a scenario written by French Egyptologist Auguste Mariette. Aida was first performed at the Khedivial Opera House in Cairo on 24 December 1871, conducted by Giovanni Bottesini. Overview: Aida, an Ethiopian princess, is captured and brought into slavery in Egypt. A military commander, Radames, struggles to choose between his love for her and his loyalty to the Pharaoh. To complicate the story further, Radames is loved by the Pharaoh's daughter Amneris, although he does not return her feelings.	128520 0000
5	A14X336I B4JD89	02018 91859	How many Nocturnes does it contain? All of them? Some? Unable to determine contents therefore, hard to decide if this is what I need/want.	135043 2000
6	A2HR0IL3 TC4CKL	05770 88726	this was written for Carin Levine in 2008, but not premiered until 2011 at the Musica Viva Fest in Munich. The work's premise maybe about the arduousness, nefarious of existence, how we all "Work" at life, at complexity, at densities of differing lifeworlds. Fernyhough's music might suggest that these multiple dimensions of an ontology exist in diagonals across differing spectrums of human cognition, how we come to think about an object, aesthetic shaped ones, and expressionistic ones as his music. The work has a nice classical shape, and holds the "romantic" at bay; a mere 7 plus minutes for Alto Flute, a neglected wind cadre member. The work has gorgeous arresting moments with a great bounty of extended timbres-pointillistic bursts "Klangfarben Sehr Kraeftig" that you do grow weary of; it is almost predictable now hearing these works; you know they will inhabit a dense timbral space of mega-speed lines	137116 8000

id	reviewerID	asin	Content	unix Review Time
			<p>tossed in all registers;still one listens; that gap Freud speaks about, that we know we need this at some level. . .the music slowed at times for structural rigour.. . we have a dramatic causality at play in the subject,(the work`s title) the arduousness of pushing, aspiring, working toward something; pleasurable illuminating or not, How about emancipation from itself;I guess we need forget the production of surplus value herein,even with the rebellions in current urban areas today; It has no place. . . these constructions are leftovers from modernity, the &quot;gods&quot; still hover. . .&quot;gods&quot; that Ferneyhough has no power to dispel. . . . All are now commonplace for the new music literature of music.This music still sound quite stunning, marvelous and evocative today,it is simple at some level, direct, unencumbered and violent with spit-tongues,gratuitous lines, fluttertongue,percussive slap-keys,tremoli wistful glissandi harmonics, fast filigreed lines, and simply threadbare melos, an austere fragment of what was a melody. . .Claudio Arrau said someplace that the performer the musician must emanate a &quot;work&quot;; while playing music, a &quot;struggle&quot;; aesthetic or otherwise, Sviatoslav Richter thought this grotesque, to look at a musician playing the great music. It was ugly for him. . .You can hear Ms.Levine on youtube playing her work, she is quite convincing, you always need to impart an authority,succored in an emotive focus that the music itself has not succumbed to your own possession. You play the music, it doesn't &quot;play&quot;; you. . . I'd hope though that music with this arduous construction and structural vigour that it would in fact come to possess the performer. . .it is one of the last libidinal pleasures remaining. . .</p>	
7	A2DHYD7 2O52WS5	06340 29231	<p>Greg Koch is a knowledgable and charismatic host. He is seriously fun to watch. The main problem with the video is the format. The lack of on-screen tab is a serious flaw. You have to watch very carefully, have a good understanding of the minor pentatonic, and basic foundation of blues licks to even have a chance at gleening anything from this video.If you`re just starting out, pick up the IN THE STYLE OF series. While this series has its limitations (incomplete songs due to copyright, no doubt), it has on screen tab and each lick is played at a reasonably slow speed. In addition, their web site has downloadable tab.However, if you can hold your own in the minor pentatonic, give this a try. It is quite a workout and you`ll find yourself a better player having taken on the challenge.</p>	111957 1200
8	A1MUVH T8BONL5 K	06340 29347	<p>I bought this DVD and I'm returning it. The description and editorial review are misleading. This is NOT a Clapton video. Certainly some clips from Clapton, but generally this is a &quot;how to&quot;; video. Same applies to Clapton The Early Years!</p>	112933 4400
9	A15GZQZ WKG6KZ M	06340 29347	<p>I was looking for a concert, not instructions to play his songs. A total waste of money. It should have said that it was for instruction.</p>	138758 4000
10	A16WE7U U0QD33D	06340 29347	<p>If you are an unabashed EC fan (as I am), you must own thispiece of history!! It takes you from the obscure artist he wasin the early years,to the Mega-star he is today!! Your EricClapton library won't be complete without it!!</p>	112821 1200

id	reviewerID	asin	Content	unix Review Time
11	AXMWZY P2IROMP	06340 29355	I was carefull to choose this DVD because it had early work on it , but i was dissappointed by the level of instruction. Even though i feel it is aimed at beg. to intermed. players the guy who is `instructing` could really do a beter job of spelling out the riffs and runs. for example he might say `ok this song starts with some hammer-ons and pull-offs (plays riffs) and then goes into A7 to Gmaj` just as an example. This is frustrating because i end up rewinding many times to make sure im playing the correct notes- what would be so much better is if he took the time and effort to say ` this run startes 2nd fret on the G pull off to open G then...` and so on spelling out the notes. this assures accuracy and ultimately saves time and frustration (I feel strongly about this because i have purchases other DVD`s that are dome that way and the difference is noght to day)Also not all songs are not complete- for example white room is missing solo-layla is missing outro solo so its just studies of the songs reallyAfter watching, i kinda feel my money would have been beter spent on a book of TAB, but at the end of the day i feel i will get a handle on the songs that attracted me to this DVD , but buyer be informed!	135241 9200
12	A1MUVH T8BONL5 K	06340 29355	I bought this DVD and I'm returning it. The description and editorial review are misleading. This is NOT a Clapton video. Certainly some clips from Clapton, but generally this is a "how to" video. Also applies to Clapton The Solo Years.	112933 4400
14	A28YJZC V43ZWQ W	06340 29355	I've played guitar for over 40 years, but it's been mostly folk music and classical and I only got bitten by the Blues Bug about 2-3 years ago - and EC was the prime reason for that (and also for my initially starting guitar back in `67 when he was in Cream, but I was looking at it more from a Rock than Blues perspective back then, not understanding when I was 15 how Rock evolved and is based on the Blues).I first used this DVD to learn White Room and Sunshine of Your Love - Doug Bodouch is fantastic at playing and explaining how and why Clapton played it the way he did. I was able to join a Blues Band playing lead guitar only a few months after buying this because of the proficiency I picked up by learning and playing along with Doug on these DVDs (I also got the Solo Years and Acoustic Classics).These are HIGHLY recommended by me, and no where does it state these are lessons *BY* Eric Clapton (good luck finding that!).Jim	120648 9600
15	A2I4CV4P GZCNAF	06340 29355	This isn't worth your money. Doug runs through each song in about three or four minutes, he doesn't give you time to learn it.Unless you've already mastered transcribing (and then why buy this dvd?), you're going to be left to rewinding a million times to get the right notes.This is no better than a youtube video of someone playing a bunch of clapton songs.Doug doesn't even show you the rhythm or other guitar parts! You're left only knowing the lead!What sense does that make?	127172 1600
16	A1M7OW NI93N1Y3	06340 29363	As much as I like doug boduch as a guitar player and teacher, All songs on this particular dvd,were not explained as they should have been. He plays at tempo, then starts playing slow, but without saying what fret, string etc, sould be played (no tab either)...On one part he even states: "you play this chord,over here, and then you play this chord" wow, that was clear..go figure..Also, NONE of the picking form, or right hand patterns were explained, when the picking part was intricate..Maybe it was a producer's order to	136589 7600

id	reviewerID	asin	Content	unix Review Time
			"teach " this way, but really I was very dissapointed, I expected more. Since I own the tablature book, I didn't have any problem with following the dvd, but if you don't, well, you are in trouble. The dvd is a very good complement for the tab book, or else, SKIP it.	
17	A2FEDDU HQAEN97	06340 29363	THIS IS NOT A CLAPTON CONCERT!!! IT'S AN INSTRUCTION MANUAL BY SOMEONE NAMED DOUG BODUCH TO TEACH YOU HOW TO PLAY IN THE CLAPTON STYLE. I WAS VERY DISAPPOINTED AND RETURNED IT UNOPENED	111749 7600
18	A338HVU M4AWJY7	06340 29363	For those who may not know the Hal Leonard publications and the Signature Licks Series: this is not a DVD of an Eric Clapton show! This is an instructional DVD for those who wants to play acoustic guitar.The instructor is Dough Boduch, a freelance guitarist, teacher, editor and recording artist. He teaches how to play (in the acoustic guitar) 8 of the Eric Clapton tunes presented in Eric's CD/DVD "Unplugged". Songs are: Change the World, Circus, Layla, Malted Milk, Nobody Knows You When You're Down and Out, Signe, Tears in Heaven and Walkin` Blues.I think the quality of the image is very good and clean. The sound is also great - when Dough Boduch plays the acoustic guitar, he sounds almost as Eric Clapton in the CD/DVD.After presenting part of the music at the regular speed, the instructor breaks it in several parts, then explain and shows part by part of each song at a very low speed (sometimes more then once) in order to make you get to the point.There is also a chapter used to tune the guitar. The instructor is very good and explains very well. The DVD could be a little bit better if we could have the TABs of the songs, but they're available neither on the DVD nor on a web-site. It seems however that if you get the Hal Leonard "Eric Clapton - Unplugged" play along book you will get there - I haven't check it yet.One interesting section of 15 minutes is dedicated to the techniques used by Eric Clapton and how he uses them: bending, vibrato, pull-off, hammer on, fingerpicking, blues scales and C Minor scale.One more cool section is the jam along section where the video shows the instructor playing but you can't hear him. Instead, you can be Eric Clapton for a day and play the acoustic parts of the song in a Acoustic Guitar Karaoke.To summarize, I found this to be an excellent instructional video, specially for those who are Eric Clapton fans and who already have a knowledge in playng the acoustic guitar. Beginners (such as myself) will probably have to work a little harder before getting the most out of this DVD.	118203 8400
19	A16WE7U U0QD33D	06340 29363	No EC collection would be considered complete without theacoustic side of EC, because the man himself is MUCH morethan just the electric guitar!!	112821 1200
20	AKKQM6 B0KI6F4	06340 29363	Very disappointing. This was advertised to be a "note-for-note" lesson on selected Clapton tunes, and it was not even close. There was no tab to support the little (and sometime inaccurate) portions of the songs that were listed. I sent a complaint directly to Hal Leonard, but never received the courtesy of a reply.	127267 2000
21	A1BX81N	06340	I'm too busy using it to take time out to review it. I suggest that you	136987

id	reviewerID	asin	Content	unix Review Time
	79C9BVT	50028	get it, I did.	2000
22	A11ER380 1T7KRP	06340 55429	This is a basic instructional DVD . If you are looking to learn buy the Tomas Cruz volume 1,2and 3 . Look no further .	137263 6800
23	A175UOH OVXRYM W	06340 55534	So, you have a pile of guitar instruction books, maybe some videos, too. Yet, somehow, you just can't make progress in your studies. You look at the profusion of guitar instructional materials out there, and wonder which one of them will finally turn you into a guitarist. Well, wonder no more. Happy Traum's DVDs are the only ones you'll ever need. Traum is an experienced and engaging instructor who has the unique ability to zero in on potential problems and tell the student exactly how to overcome them. His lessons go quickly, but he leaves nothing out. Follow his pace, and his advice about when to shut off the DVD and go practice on your own, and you'll be handling those chord changes on time in no time. It's time to move beyond G/C/D and become a real guitarist, and these are the DVDs that'll help you do it. This set is the jumping-off point for Traum's many other instructional DVDs. Whether your interest is bluegrass, country, blues, fingerstyle, or whatever, start here. You'll get an excellent, easy-to-understand grounding in guitar technique and theory. After that, you can move onto one of Traum's other DVDs to explore your favorite genre. Oh, great! I've just re-read what I've written, and I sound like some slick salesperson. I guess it's because I'm so relieved. After two years of false starts, I'm finally learning how to play. Thank you, Happy Traum!	121409 2800
24	A2P1Z9N UJ9HIRT	06340 55534	Bought this for my grand son that just started playing guitar and I know from past experience with Homespun Tapes that this will really turn the light on for him...Thank you Happy Traum for introducing this brilliant teaching concept !	136728 0000
25	A1D1S69Z MKYCCV	06340 61801	great book... you should be aware of blues scales and have a little practice before using it but it will help you a lot. After a few exercises you'll notice some improvement on your style..and 50 licks is more than what you need...cheers from Costa Rica...surf town :)	128900 1600
26	A7R79JLQ 5Q28M	06340 61801	While I did not enjoy Mat's "Blues Rock guitar soloing" DVD, I did enjoy this one.It is very straightforward, with Matt playing and explaining 50 blues licks. The licks start with turnaround licks, and are easy to learn and incorporate into my own playing.One minor complaint is that there is no context for the licks other than what Mat mentions. I think it would be more beneficial to the player to actually listen to the licks in a musical context (i.e., played with a band or a backing track).This is a useful addition to the blues player's (and student) arsenal.	112492 8000
27	A3T7SXC KJUXT3	06340 61801	This was a very pleasant suprise i really enjoyed this dvd.It challenges you to learn and play these very usable and desireable blues licks.In this dvd are the great turnaround lick's that have been used for years on some of the best blues solo's , I instantly began using what i had learned from this dvd in my solo's.The one drawback is the DVD menu i found myself back at the start menu many times.This is the type of dvd that helps you take your soloing to the next level.But if you are new to guitar this would be a frustrating ride,I would estimate that the people who would benifit from this should be at least intermediate to advanced level....but	119085 1200

id	reviewerID	asin	Content	unix Review Time
			everyone is different.This dvd is one of the best blues insrtuction i own.	
28	A1JZM0YI YHL6JW	06340 61801	I've been playing the blues for a long time so I wasn't particularly inspired by any of the licks. I didn't find the `gem` that I didn't recognize to add to my vocabulary, the one illusive moment i was looking for... nevertheless, every one of these licks is the `meat and potatoes` vocabulary that can be used to talk the talk. Mat does an outstanding job of guiding you through these 50 licks with real clarity. I like that he uses the actual names of the notes instead of naming the string and fret for reference. I can see that Mat`s a real musician and has a masterful handle on his axe. I went through it in about a week and had a good time doing it. I like that the DVD format defaults to the menu after the lesson to give you time it `fool around` with the lick and squeeze as much as you can out of it. I really enjoyed it. Good stuff.	127068 4800
29	A372SXZ3 9TUW TZ	06340 61801	Mat and would not hit it off. Instant personality clash for sure. Then again I didn't buy this DVD to make friends. I bought it to learn blues. 50 good usable licks presented in a way that you can actually learn them. Good camera angles, the sound is fair. Tab could be onscreen but I guess the booklet works just fine. Just the thing for the early intermediate player.This DVD spends a lot of time in my player!	112268 1600
30	A331DOW XV50UMT	06340 61801	Some really cool riffs that can be incorporated into your playing - Instructor could have spent a little more time explaining and breaking them down, but I guess they had to stay within a certain allotted recording time	128865 6000
31	A16ZE9M J0703UB	06340 61801	This wasn't for me..but for my husband who enjoys anything guitar. He learned some new ideas and enjoys going back to this and seems to learn something new each time. He is not a beginner and not a pro either.	139726 0800
32	A3DM7A DJV144TZ	06340 61801	this is a cool video and has some killer licks in it, but as stated above, this is not for novices. it is very fast paced and unforgiving. great for the upper level intermediate who has maybe hit a bit of a wall and just needs some fresh ideas.	136581 1200
33	A2FIMQI KNOHFP K	06340 61801	I am a professional musician with over 17 years experience on guitar alone and this is the second DVD in this series I have bought now as I was so impressed with the first which was the Country licks. At the outset it should be said that these DVD`s are not for beginners, sorry but that`s just the facts. This isn't to say that a beginner cannot glean inspiration and work up to certain licks slowly but I would suggest this really suiting the intermediate player to advanced on some techniques.With my many years of playing I was already familiar with the techniques being employed on this DVD and found myself ripping some awesome licks in just a couple of hours after sitting down and viewing it. Even for an old dog like me I was learning how to lay down certain phrases I was always curious about but never got around to ... such as some of the faster flourishes.The sound and presentation are simple and yet excellent with both right and left hand views on screen at the same time. Mat Gurman does a fine job of breaking down the phrases and is technically excellent in his own right. I have had no issues with the Tab that comes with this DVD	119059 2000

id	reviewerID	asin	Content	unix Review Time
			<p>NOT matching up with what is being played ... every note was where it ought to be. A final note ... don't be put off by the return to menu feature, I have found this to be a smart addition to this series since it allows you to stay with that lick until you got it locked in before moving on without having the DVD race away from you while you are working things out. This also makes each lick easy to find and return to rather than having to scroll through to locate it! For this kind of value I plan on getting the Jazz and Rock DVD's in this series - my vocabulary has really expanded in the time I have spent with this product and I am already an advanced player. If like me you are an experienced guitarist you may find you only need 10 or more of these licks but I'd be learning them all because they can often transform into other licks you create yourself. Killer series!</p>	
34	A1QVR0Z IG59ZAG	06340 61801	<p>My Background: In order to level set you as to my comments here is a little about me. I have been playing pretty consistently for about 1.5 years. I still consider myself a novice guitar player. I know 1/2 dozen cords, a few songs, some typical beginner licks and have been practicing the A major and A minor pentatonic scales both in the first position. I am pretty good with those two scales. I have no problem reading most guitar tablature. What You Need To Know This is just my opinion. It is key that you can read guitar tablature. Also, it would be VERY helpful if you knew many (more than I do) of the pentatonic scales and several of the positions for each (there are 5 positions for each scale). Mat (the instructor) only shows you one scale and in a single position (A Major &quot;Blues&quot; scale). He does this very quickly at the start of the DVD. It would also be very helpful if you are proficient at bends, hammer ons, pull offs and slides. You will also do better if you have some skill in a few different strumming techniques, including muted tones. Clearly all of these are key elements of blues guitar (actually any guitar work) and he uses them in abundance. The Instruction and Licks: As I mentioned he does show one of the scales he calls the &quot;A&quot; blues scale. However he is all over the place on the fret board (uses far more than just this one scale) and if you don't have some degree of proficiency in playing scales you will not get much from this DVD. He also shows you quickly how to tune a guitar. However I'm guessing that anyone who would remotely be able to use this DVD would already know how to do that. The licks he shows are very cool and if you can learn some of them they can be strung together to really jam. They range widely in level of complexity. There are a few that could be played by a beginner who has little experience (although they are the exception). Any beginner trying to learn these licks would have to be highly motivated and determined. Mat does include the tablature for each of the licks which is very good. In most places on the DVD he shows both of his hands so you can see the fret work as well and the picking. He does slow his playing down and for the most part you can figure out what he is doing. However he is so versed in what he is doing that he does sometimes make assumptions that you understand what he just did or what he is telling you. This is where it will be difficult for beginners. Bottom Line: Pretty cool DVD. With my current skill level I will be able to make some use out of it but by in large it is a little beyond me still. That said I am still very happy I bought it because I am sick of just practicing scales up and down, up and down, without doing anything cool. You can not even get 30 minutes of live guitar lessons for \$10. The DVD is done well enough such that if you have some ability to play and want to check out some cool licks it is well worth the</p>	118765 4400

id	reviewerID	asin	Content	unix Review Time
			money.	
35	A2788UY AD532T	06340 61801	Having recently revived my desire to improve on the guitar, I purchased this video. I had just purchased another DVD with which I was very happy and decided that any decent guitarist needed some blues licks in their repertoire. I had a more difficult time following along with this one than I did on the previous purchase. This one comes with a hard copy of the Tabulature but I'm convinced that in many places, the Tabs don't match what he says to play or actually does play. That's a little frustrating for me. I do give it 3 stars because I do think as I improve, there will be some learning opportunities, but at my current skill level, it's a bit over my head so that makes it not very valuable for now. Perhaps there should be a grading/age/skill level system like they do for kids' toys that allows for consumers to judge how advanced you need to be to get value from a product or if it's even suitable.	117840 9600
36	A1746NH DF3PF3H	06340 65459	After performing bottleneck gospel/blues professionally for the past 12yrs I've noticed a trend amongst my generation (30somethings) of players which concerns me greatly...wild, fast, sloppy playing sounds more authentic. I have had numerous conversations with fellow players attempting to convince them that fast and sloppy playing isn't more authentic, it's just fast and sloppy playing. Brozman makes it a point to address just that in DVD 1. He states that the originators were trying their best to play as clean as possible but due to bad strings, bad guitars and pretty lousy recording equipment it created a challenge to do so, although many did achieve very clean playing (Tampa Red, Blind Willie Johnson, Robert Johnson, etc.). DVD 1 is critical in learning the fundamentals of control, both with slide and picking. I highly recommend DVD 1 for any players. DVD 2 covers classic delta blues material Brozman style. Plenty of "tricks" to be learned even if your not looking to sound like a Brozman copy. DVD 3 expands into more open tunings. Again, plenty of "tricks" to be learned. Whether these are too advanced for the beginner I cannot say because I'm not a beginner. I can say that minutes into DVD 1 I wished I had these DVD's when I was learning because it's taken me 12yrs to acquire the skills I could've learned in months of working with these lessons. ALL in all these DVD's will help get the wheels of creativity flowing in your own playing...and playing clean.	129591 3600
37	A26LIKTL 5KW29E	07390 03755	This is a two CD set each CD is 30 minutes long. The second CD is for the "music discovery book", I love this CD, it is just perfect for group music classes and it is a fun CD for kids to just listen to. There are 25 songs: a hello song (mentions mozart mouse and beethoven bear), a goodbye song (could be used for any program), 8 rhythm instrument songs, 5 movement/music appreciation songs, and 8 listening/ear training songs. The first CD is essentially a "book on CD" of the "music lesson" book and I don't see why you would ever use it because a teacher could read the story herself much more entertainingly.	121262 4000
38	A4TE45T H7L2MW	07390 03755	The Discovery CD has songs for singing and movement. There are some original songs as well as familiar tunes. The Listen and Sing examples are short, easy songs to help students learn solfeggio syllables la-ti-so-re-mi. The Lesson Book CD tells the story of	131198 4000

id	reviewerID	asin	Content	unix Review Time
			Mozart Mouse and Beethoven Bear exploring the magical music book as they learn to play piano. Children play with their plush toys and play piano/keyboard along with the lessons. The lessons are well organized and fun for very young children. Some of the songs on the Discovery CD include: Hello Song If You're Happy and You Know It Racing Car Clownin' Around Finger Play Song Hickory Dickory Dock Mexican Hat Dance Beethoven's Rage Over the Lost Penny Mozart's Variations on Twinkle, Twinkle Old Mac Donald Had a Farm Mister Elephant's Funky Dance Sousa's Stars and Stripes Forever Giant's Lullaby Do Re Mi Tapping Song Minuet in F Beethoven's Symphony No. 5 Twinkle, Twinkle Little Star Put the Beat in Your Feet Goodbye Song	
39	A732DZL EGXSEQ	07390 03755	This CD is absolutely awesome. My daughter loves listening to the stories of Clara Schuman Cat, Beethoven Bear and Mozart Mouse. There are stories to listen to as well as wonderful renditions of the songs in the book. They have two differently played songs which helped my daughter a lot. It would be nice to have one of the renditions have the songs sung. Having to learn 10 songs for her recital with every song using the same 5 notes made it difficult for her to remember them all as they sounded so similar.	133729 9200
40	A142DE4 DV7NKT Q	07390 03755	As a lifetime piano teacher, I love this child-friendly piano method for young children. Content is rich with a variety of musical experiences. And I have fun too with Mozart Mouse and Beethoven Bear. Its great to see the level of interest and readiness of a student.	139078 0800
41	AAUICX M1YE8L	07390 03755	Just like the previous reviewer says, the two CD's are great in contents. For some reasons, however, my set came with labels switched around. The one that said "Music Lesson Book 1" was actually for "Music Discovery Book 1" and vice versa. There must have been a mistake at the manufacturer.	129790 0800
42	A153V2Q D4BJT1Z	07390 03755	We are very happy with this series. My son has special needs and benefits from music therapy weekly. This series teaches about musical concepts with a story book format. We also bought the companion CD and stuffed animals.	136408 3200
43	A153V2Q D4BJT1Z	07390 03755	We are very happy with this series. My son has special needs and benefits from music therapy weekly. This series teaches about musical concepts with a story book format. We also bought the companion CD and stuffed animals.	136408 3200
44	A2TKRYC SIPOPOA	07390 03755	We absolutely love this line of books. My 4 year old is now on the third set and playing away! It's made her lessons fun and easy. And I love that she can play with the cd's accompaniment.	135941 7600
45	A25UM6A 6A4SEDT	07390 37986	I would recommend this DVD to anyone interested in the construction and the materials in which pick ups are made from. The history of the Semour Duncan Company is fascinating. Anyone wanting a basic understanding of how pick ups works do yourself a favor and buy this DVD.	122990 4000
46	ADM67P7 K66F41	07390 37986	This is a great video with lots to learn and see. It is basically a tour of the SD factory, with interviews with the Duncans. This may have started out like a fluff piece documenting the company, but I really liked it. SD shows how he changes out pick-ups, very cool. And it	123171 8400

id	reviewerID	asin	Content	unix Review Time
			has a great educational section on the development, sound, and design of their products. Good. Great info available elsewhere in print and on the web, but if you like moving pictures and like a good guitar story then \$20 for this video is worth it.	
47	A18C8JY M2161KE	07390 37986	This was terrible. It gets right to the part you need to know to solder the pickups and then cuts and shows pickup already installed. I really dont see how anybody approved this for sale. If you are looking to learn how to install pickups and save yourself money at the guitar store - this DVD is worthless. Again, the video footage cuts ahead at the critical point that would show you which wires to solder where. so disgusted.	121979 5200
48	AK3MEB CSQ18LO	07390 37986	I didn't think it was worth the money !I have used his pickups and they are fabulousBuy his pickups but skip the DVD !	120251 5200
49	A307SOX S9WP4GI	07390 40251	If you want to know how drummers that have made it actually drum, you'll want this video. If not, you won't.	135993 6000
50	ASP16LV GFITDE	07390 40251	As a drummer of 40+ years - (recovered, but relapsing constantly) - Simon Phillips becomes my new hero with this video. His polyrhythmic ambidexterity seems effortless and natural, and his behind the scenes comentary and instruction are concise, thorough, and easily absorbable. A must-have DVD for any drummer desiring to improve his skill set. Five Stars!	128831 0400
51	A2HYLAE SK4RRTI	07390 40251	I like Simon Phillips, I think he is one of the best drummers in the world. This video however, was obviously made a long time ago because he looks very young in it. I admit I saw the cover and could see he appeared to be much younger, but because the video had been remastered and redone I hoped some of his more recent performances might be included, they were not. I still enjoyed it but wish he would bring out something containing more recent material.	139285 4400
52	ASEVEFG 1SSYJK	07390 40251	He shows the grooves and beats in a slow enough speed to understand. He even breaks up longer patterns into sections to see what he's doing. He's a ambidextrous player for sure and much like Billy Cobham has some serious stamina to not only play 100 miles an hour, but keep the pace for a whole show. I had a chance to see him locally recently and he's pretty much the way he comes across on his video. As his playing is double bass, I would recommend it for those with 2 bass drums. He was much younger in this video and still plays the same style and speed. No real time spent on simple grooves and patterns, thus I'd say it was an intermediate level instructional video.	139872 9600
53	AARB5F3 HPXV0V	07390 40251	If you have not seen Simmon Phillips play, this is the DVD to see!This is closest your going to get to Simmon Phillips Mastery!What an incredible player he is, my hat is off!!If your a drummer or a music lover for that mater, this is a must see!!!	119206 0800
54	AQFYZ8N 5SQ1Y7	07390 40251	This DVD is the complete set of what had previously been 2 separate vhs tapes. Simon's playing is, of course, incredible. For any drummer interested in Simon's playing this is a must. There are some advanced concepts here, but Simon is extremely good at explaing what is going on in simple language. For those who are more musically literate there were two instruction books based on	119629 4400

id	reviewerID	asin	Content	unix Review Time
			the videos. The video can be seen as a progression from simpler (well simple for Simon) material to more advanced. Something like `Cosmos` can be approached at a much easier level than say `Force Majeure.` The section on Odd Time is great, and if you buy the instructional books, there are play-alongs to all of the material. Also, in terms of sheer performance Simon is always so exciting to watch that even if you don't play drums near that level, you will love the `Concert` footage.	
55	A1Z5471U G451G9	07390 40251	Simon is really taking it to the extreme and the performances in these videos are very inspiring. I suppose even less experienced drummers can benefit from looking at this as it contains good basic training techniques. It also covers tuning and even mixing, so this is really something to smile about for all us drummers.	126887 0400
56	A2PI3IIBP G2VI2	07390 40251	I imagine Simon Phillips needs no introduction indeed, so we can skip that part. The amazing thing about this long awaited DVD is the fact that all these great and complicated stuff Phillips executes are within the context of great music, written by him and performed with two other great musicians otherwise, what would be the point of such amazing technique and skill? Through very clear chapters Simon explains how to tune, why he position himself like that behind the kit, etc., in a humble way only great talented people can show. The double bass technique is explained and shown in a very useful and understandable way so you can play or practice along. He is miles away from showing himself off with what he's doing which seems to be the usual these days. And the sound of that kit? In my humble opinion that's the way a drumkit should sound, wide open, lots of projection and sweet tom-toms sound since he plays off the heads instead of whacking the kit, which is the current tendency. Listening to this DVD, even though I still haven't done it 5.1 is an enjoyable experience not only for drummers but for anybody who appreciates great music. The tracks performed are in that interesting area among jazz, rock and fusion so there is something for everyone here. The interview with Simon talking about the 5.1 mix, which he did entirely is very interesting even for us not so involved in recording matters. Least but not last, even though this DVD has no subtitles, is perfectly understandable because of Simon's slow and plain British accent, so it won't be a problem for any audiences worldwide. Five stars/thumbs for Simon....again!	122584 3200
57	A370T379 VAAP4B	07390 40251	overall in informative and entertaining video. some experienced drummers may fast forward the tuning and practice segments. too bad the updated commentary of making the video doesn't include recent footage of performance.	122644 8000
58	A2BXUV0 43WWTK W	07390 40251	I was looking for more of a teaching feel to this video, but the video is a good video because as a drummer you can pick up on some real cool licks. I would recommend this video to any skill level drummer.	135017 2800
59	A1PXB40 VLPLT4H	07390 40308	John Patitucci is not only an amazing player, but also an incredible teacher and offers insights into a myriad of essential & beyond aspects of musicianship on this DVD. Highly recommended for intermediate to advanced bass players looking to expand their playing in a big way!	120458 8800

id	reviewerID	asin	Content	unix Review Time
60	A2RI4VW 44924NH	07390 40308	One of the greatest bassist alive!! I really enjoyed this DVD, it helps you with technique, groove and to understand multiple rythms and how to approach each one	136028 1600
61	A3O2TMY U7E1V81	07390 40308	i thought it involve small hand bookbut it`s only DVDbut, the information is so good	125375 0400
62	AVBWSI1 9JRCPQ	07390 40308	Patitucci is an excellent teacher, but not entirely comfortable in front of camera. He covers most of the basics: posture, left and right hand action, strength/flexibility/independence exercises: spiderwalking, pulloffs with other fingers locked. The harmony/theory sections assume you have a decent command of the basics.The bonus footage of him and Steve Bailey, and of Jaco (clips from other Alfred DVDs, i think) are fun to watch.Some drawbacks of DVD version:- a lot (50%) of footage uses 6-string, which is still relatively uncommon, and forces you to figure your own fingerings/transposes if you don`t have one.- much of the footage after the initial clinic chapters, JP playing with recorded backup or with Drummer D Weckl live, is not close up, so not that helpful. YOU can listen, you can`t watch JP`s hand action carefully.- sound is printed through on original analog master tapes, i.e. you can hear a faded "preview" of Patitucci talking before he starts talking. Not a big deal.	122973 1200
63	A2WNDXI NN9PXEL	07390 40308	This is a great basic instructional DVD, John goes into some great fingering exercises to build dexterity and strenght that all good bass players. Recommend this as one of the basics of a good instructional library.	127059 8400
64	AZY4GP1 W5N5KO	07390 40308	Just the perfect video to get everything about bass, rhythms, techniques, soloing, theories, harmony, styles, etc.John Patitucci is master	139803 8400
65	A1JHCSJL JA3M21	07390 40308	This is not what you`re thinking. This DVD is merely two hours of the "flamboyant" John Patitucci playing songs. He does not show any of his riffs to you, he plays them at full speed so it takes forever to find the pattern. This is \$30.00 I`ll never have back!	119352 9600
66	A3FYON MMFY4V K6	07390 40375	I own every Paul Gilbert video that I am aware of. These two volumes have dramatically improved my technique, speed, phrasing, picking, etc. Paul is an amazing teacher. He explains everything in depth so that even the novice guitarist will understand most everything covered. I own many other videos including Yngwie, Vinnie Moore, Richie Kotzen etc. None of the other videos can compete with the Paul Gilbert videos. I often watch Intense rock 1 and 2 as refresher courses or just for plain entertainment. If shred is your game, then look no further. Learn from the best!	117339 8400
67	A31NJVE7 JDIPR2	07390 40375	I`d already seen a few of the lessons online and there was no doubt on what I was in for.A detailed shred of shredding. And Paul Gilbert is a fantastic teacher. And a great artist. He really rips apart his own technique and shows you the light... the rest is up to you. Whether you have the motivation to DO and practice consistently and accurately.If playing fast is the real thing on your mind. Just pick up this DVD and hear your self transform in a matter of months.I used to have this fear of speed. Thanks Paul for dispelling completely. And making it accessible for mere mortals. While I still am not sure I can ever get to the clarity levels that he has on his fast ones... I am	121331 5200

id	reviewerID	asin	Content	unix Review Time
			definitely not scared anymore to attempt to play fast...Thank you very much Paul Gilbert.	
68	A1HXA6Y KQJ7FNT	07390 40375	I read good reviews about this guy and this video. I even saw some clips of him on youtube and that convinced me to buy this. However when I got it and watched it, I noticed he went too fast in his instruction for me to keep up. My biggest gripe is that he does not teach you the rudimentary techniques such as how to hold the pick so that you can pick as fast as he is. I found myself pausing the video a lot just to get the lick. The DVD comes with a printable PDF booklet (13 pgs). This is def not for beginners. It would have been better if he started out showing you how to use a metronome in shredding and subdividing notes. The included sample vid with John Petrucci (he shows you shredding with a metronome) was what this video should have been.	121651 2000
69	AFA6HGI 3MW3SA	07390 40375	I just got this dvd a few weeks back and I can already feel a noticable improvement in my technique. In the first section, he goes over picking, 3-note per string scales, chromatic and harmonic minor licks, hammer - ons and pull - offs and different arpeggio techniques, including sweep picking and string skipping. In the second section, he gives more practical applications of the techniques and offers insight on how to improve phrasing and how to practice soloing. Paul is a great teacher and he will keep you interested both with his playing and his sense of humor.	117374 4000
70	A1FPATL QSFTLC9	07390 40375	... at a price that cannot be beat. the product contains both of paul's first 2 dvd's and offers a huge selection of over-the-top shred guitar. i had the 1st vhs way back in the day (the 80s!!!) and just about wore it out so i had to purchase this item just to have. if you want to take your guitar playing to the next level and save some coin in the process, get this.	133591 6800
71	A30TM3E BHF2C7R	07390 40375	There'd be a lot more amazing guitarists in the world. Intense Rock I is mainly directed at improving technique providing a lot of different 3-note-per-string, string skipping and sweep arpeggios sequences. Paul does a great job at breaking these things down while giving us a taste of his goofy sense of humor, but for my money Intense Rock II is king. Among other things Paul covers dynamics and control, and the last segment on practicing alone is worth the money. Do yourself a favor and pick this up, your guitar will thank you.	120873 6000
72	A2WIO7V LFWV4Y V	07390 40375	Within a month I have already notice some serious improvements in my playing. Particularly my picking is much cleaner. Also, it's nice to add some more licks to my library...I was getting pretty bored with my playing for a while, but this video has revived my playing once again!	126748 8000
73	A2GAXE9 X97WYT W	07390 40375	Paul's ability to teach is amazing. VERY relevant and ALWAYS fun! For 20 years now he has been and continues to keep things easily understood that are essential in taking your technique to a new level. As a player whom has been playing for 30 years now myself, Paul's breakdown of left and right-hand technique finally got me over the "hump"; I had not been able to overcome most of my guitar playing days as I finally overcame a plateau and quickly saw noticable improvement in speed and accuracy as I finally got the	119689 9200

id	reviewerID	asin	Content	unix Review Time
			metronome setting to click higher than ever and still growing.	
74	A3QJ54L WTFXBIB	07390 40375	Every budding shredder needs this. I'd give it a 5 star but it lacks a bit of technical detail. Gilbert is such a impeccable player though so just buy it anyway.David[...]	123405 1200
75	A1AO3SP 66Q9ZWJ	07390 40375	Muy bueno y explicativo para todo tipo de guitarristas, ayuda a incrementar la técnica y rapidez.Excelente DVD para tenerlo en consideracién en nuestra coleccién.	138015 3600
76	AL1HYP2 66NWOJ	07390 40375	Nice lessons from the shredder King, is better start with this DVD, recommended for increase your guitar skills and fun	135466 5600
77	A1R8OFZ Y6CYX7G	07390 40375	Part 1 of this DVD is crammed with standard shred licks...but not much in the way of how, when and where to use them. In that respect, it's one of the more disorganized guitar instructional videos I've seen. Despite Paul's youth and enthusiasm,, the material gets relatively advanced rather quickly (and he can play the licks so fast and perfect, it's just as discouraging as inspirational).In Part 2, he sporadically mentions things that would be aimed at relative beginners...which definitely doesn't belong on these videos. On the other hand, Example #7 is so much more intricate/difficult than anything else on this disk, it seems out of place. The best thing on the whole disk are the 2-note per string/string skipping arpeggios (wish I woulda started practicing those 10 years ago). There are a couple of other cool licks, but the video ends up a mess of a lot of talking...my mind wandered.Before attempting to play along, you should already know all the major scale modes and the melodic minor scale. Your alternate picking should already be very controlled/synchronized and you should be experienced with string skipping. It also contains some extreme finger stretches/intervals that a lot of people might never be able to do (a shorter scale neck or extraordinary long fingers will come in handy here).If you don't already have the skills mentioned above, I highly recommend Don Latarski`s "Guitar Theory Basics" and Frank Gambale`s "Chopbuilder" be bought first. Sequentially, they'll introduce you to all the basic mode fingerings and get your alternate picking, control and speed somewhat closer to Paul's level.	128312 6400
78	AQ46HO2 8ZVEL3	07390 40375	intense guitar lessons.	140365 4400
79	A1GUCW 7L3QYQ3 3	07390 40375	Paul goes into great detail on scales arpeggios and everything you need to sound like a pro!! I would highly recommend!!	137496 9600
80	A3TITKW 06F1W0	07390 40375	I have been playing forms of rock/metal for a few years, but never really tried my hand at leads so I figured I would give this vid a shot. I watched the video through a few times and obviously Paul is very good at what he teaches, but I got left in the dust right off the bat. I eventually decided to focus on some of the easier patterns, memorize them and run though them everytime i pick up my guitar. I am a lot faster now than before I started, but still nothing close to paul---even on the simple ones. I would say this video is more for someone that can already play fairly fast and is either looking for more licks or wants to play faster. Don't get me wrong it is a good vid, i just wish I	122385 6000

id	reviewerID	asin	Content	unix Review Time
			were more up to speed when i bought it.	
81	A35DFRN 89NRVU1	07390 40375	Anyone interested in improving their picking and articulation would be well advised to check out this DVD. There`s enough here to keep a player occupied for quite a while. Volume two of this title really drives home the point of making those tasty shred licks musical. This DVD is a fantastic deal.	120121 9200
82	A1MFT8D XOQJA9L	07390 40375	This was produced going on 20 years ago, (the 1st half anyway) but is still relevant today. After the post-grunge backlash of the early to mid 90`s it is good to see this style of playing coming back. Paul is an unassuming character whose delivery & instruction of his style & technique is very helpful & down to earth. The 1st half of the DVD was done in his early Racer X days & really reflects the licks from that era, as the 2nd half naturally exposes the Mr. Big pop oriented offerings. This DVD will either inspire you to attempt to reach his level of technique, or really discourage you. But again, I believe his good nature will inspire most. I was able to meet Mr. Gilbert at a clinic shortly after "To be with you" was a hit for Mr. Big years ago & he was still really down to Earth. A whole new generation have the opportunity to learn from him & really should make this DVD part of their library. Just do your best to ignore the 80`s-90`s "production" :) Also the addition of the .PDF files for Vol. 2 is a nice touch!	118281 6000
83	A29MLKC AZXX7AB	07390 40375	I`ve been playing guitar for years and years. Have many books, CD`s, etc. This is my first on "shred" techniques... holy cow! It`s like I`m back to square one.. but that`s good.. basic techniques are well presented in logical format. I was able to move through some of this fairly quickly, in theory, but still working on speed speed speed! Wish there was TAB for Vol.1, but I found that online. Vol.2 tab is included in PDF on disk. Would be nice if there was something to paly along with, it`s presented and you`re off on your own to practice. All that said, it`s a good bang for the buck... plenty of good techniques and lessons to work on for a long long time.	126766 0800
84	A1ZMV5Q SAR8V2L	07390 40375	Paul gilbert showing some of his favorite chops, a true innovator of the 80`sguitar era with racer x/mr.big and his solo work!!!!	138075 8400
85	A2G7DY W6ILDGK L	07390 40375	Paul Gilbert got my attention in a tiny article from Guitar World, maybe Guitar Player, back in I`d say 87? maybe even earlier. he had just won a guitar gun slinger contest in the LA area and was heade to GIT. ayway, I kept an eye out for him along the way, and sho nuff, he is a technical monster. he may not send quite the emotional chills of say, I don`t know, Eddie Van Halen (78-84 that is)? but the cat definitely sings some soul with his axe too, don`t get me wrong. I`d say, get his chops down, maybe some DiMeola master`s level stuff too if you are into fast, clean, alternate picking as I try to be, then fuse your own soul with it--put some Clapton, SRV, Jimi, and Eddie in there--don`t forget to bend it and shake it! you may come out with some really fresh, really good stylistic new frontiers--At least, that`s what I`m after. just don`t forget to make it YOUR OWN! balance in all things. this video is all you need to get started on the Gilbert part of this equation. its full, complete, and well done. His work with Mr Big is seriously good too, if a litte poppy, particularly their first two (I never got to hear too much of the later work. enjoy, work the	117460 8000

id	reviewerID	asin	Content	unix Review Time
			technique down to perfection, cleanly and slowly, then rip it up full speed when you're ready. keep this vital part of intense rock alive and then, lift your goblets of rock!	
86	AVU79AE IZQL8	07390 40375	Paul gilbert does a good job at explaining all the sequences. the only reason i don't give it a perfect rating is that part one gets kind of boring to watch, and you need to get through a lot of it in order to understand part 2.	119171 5200
87	A2FFKX7 59L9RFT	07390 40375	Best guitar instructional video that have seen in my 20 years of playing. Comes with video tabs which is great too!	138231 3600
88	A31DJ1X8 OARWYG	07390 40375	I am speaking for someone else here, but I am very very happy with my purchase nonetheless. I got the dvds for my boyfriend who is a professional guitarist and he was ecstatic! thank you amazon for having everything I can ever think of to get for someone.	129885 1200
89	ALLHLO G4NLA0A	07390 40375	This is the best purchase anyone can make if you want to shred being that finding a good teacher that can teach this skill is not easy. Paul besides being an incredible player covers all bases of Alternate Picking and String Skipping like he was in front of you. This is worth every single penny. Now you have both instructionals on one DVD for the price of one!!!!I own a vast array of instructionals, and if you only had 17 dollars to spend on a dvd, this is the best money you'll ever spent. Paul teaches shred like he was in front of you and believe me, no one possesses that skill. I also recommend his other instructionals after you are ready to move forward from this one Terryfying Guitar Trip, Get Out Of My Yard and his latest, Silence Followed By a Deafening Roar.RATING 10	116951 0400
90	A3PNCYF SZW7JQ9	07390 40375	I actually bought this video (vol 1) when I was 11 or 12 when it first came out with my allowance that I saved up. As a guitar teacher and someone with 20 plus years playing experience, I can say that this is the best video on shred guitar technique. Volume 1 alone is well worth the price. My only issue(a VERY minor one) is that he doesn't talk about the metronome and its usage. But any good teacher can explain that in about 2 minutes.Volume 2 while not quite as shred heavy is still a great dvd to have(and just as important content). It concentrates more on phrasing, dynamics, rhythmic ways of building phrases, etc. Don't worry, there is still plenty of shredding as well.These volumes are the best investments I ever made as a guitar player,teacher and student. Anyone who wants to learn how to shred, get this dvd package, and a book on music theory(or instruction by a teacher) and a good chord book and you'll have everything you ever need.Keep in mind, no matter what, you still have to practice(alot!!!!). No book, Dvd, or anything is going to MAKE you play well. If you are a beginner(or even advanced), you still have to work hard. However, this is a big help.	118782 7200
91	A1HOME HH9SE7X 3	07390 40375	I give this product three stars because it was good. It is pretty basic. There are good lessons here for fundamentals. There are a couple of interesting arpeggio ideas, but really nothing to write home about.Consists of picking exercises and simplistic scalar patterns. Great for a player in their first few years.	136918 0800
92	A3DMR23 4MWQYS	07390	Gilbert is a master player and instructor - and I think we all know that those two things don't necessarily go together. His technique on	120484

id	reviewerID	asin	Content	unix Review Time
	E	40375	this DVD is jaw dropping. I really don't think it would be possible to alternate pick faster with the clarity Mr. Gilbert brings to the instrument. Paul seems to have both sides of his brain fully developed - the artistic left side that rocks out with gut searing intensity and emotion, and the geeky analytical right side that can perfectly explain and break down why it all works. I own literally thousands of guitar instructional materials that I've purchased over the last thirty years, and can honestly say that this DVD ranks in the top three. If you are at all interested in shred guitar, you simply have to buy this. Many of us paid \$40 or more per VHS tape for the original videos (parts I and II), so this DVD is an amazing bargain at this price. Thanks, Paul!	8000
93	AX5ZI7JZ MA2SY	07390 40375	I have been playing guitar for more almost 20 years and I wish I had this DVD back when I was trying to develop my shred guitar technique. Couple this DVD with a book like Speed Mechanics by Stetina and you have all you need to start shredding. Paul is such a virtuoso shred player, he will blow you away with licks played at the speed of light!! He however slows all these licks down and even shows every small detail in achieving these licks from alternate picking, sweeping, sequences, sweep-tap, legato and more!! You will also need a metronome and LOTS of practice time to learn these techniques. When you master them you won't regret it since you will be playing with terrifying technique. If you want to play like Paul Gilbert and other master shredders out there, this is the DVD to start with. And for this price you can't go wrong.	119577 6000
94	A1K1ZKO HP4RQT W	07390 40375	If your leads only consist of Box 1 of the minor pentatonic scale, this DVD will leave you in the dust quickly. This is only for guitar hero-shredder types that have real chops. You need to be fluent in music theory, you must have absolute command of the entire fretboard, and you need to be fast in all the scale modes to keep up with the material. The video is very entertaining and packed with info that will help any guitarist no matter your skill set; the problem is, you won't be able to play the examples up to speed. Watching a virtuoso like Mr Gilbert run up and down the fretboard at the speed of light is worth the price of the DVD. An amazing guitarist!	136451 5200
95	A1FWCID D38DYM U	07390 40375	Paul Gilbert is one of the best guitarists in the world. Lucky for us, he's also a really down to earth guy and is a great teacher. While all of Paul's DVDs are great, Intense Rock helps you lay the groundwork to play shred metal. From the first simple exercise to the last terror lick, Intense Rock is an exercise in the development of shred technique. Paul is a great teacher who actually slows down the licks and explains how he plays them. He certainly isn't too haughty to forget what it was once like to be a student. Pair this up with Troy Stetina's shred masterpiece, "Speed Mechanics for the Lead Guitar," spend most of your free time practicing, and you'll be able to shred. (There's no great secret to technique! It takes time, drive, patience, and belief in one self.) John Petrucci's Rock Discipline is highly recommended as well, since Petrucci, while less wacky and attention-grabbing than Gilbert, is a great teacher as well. Although, I would say it's better for those who've already bettered their technique, and have, thus, seen some concrete rewards for their playing. The Intense Rock (and Speed Mechanics, for that matter) exercises are very musical, and are therefore easier for the beginning shredder to practice for an extended period of time, than Rock	120623 0400

id	reviewerID	asin	Content	unix Review Time
			Discipline which has a lot of (valuable) atonal exercises.	
96	AWU110T P1HTPF	07390 40375	Paul is the master of fast guitar licks. I mean Wow!!he teaching very valuable technique that is helping me improve my speed. I've got all the DVDs and bought them for my kids too! Thanks Paul!!!Tommy G	120113 2800
97	A1JQDMD HOZTYC V	07390 40375	Thank you for my Paul Gilbert DVD. It is double plus premium and A-Okay! I now own Paul Gilbert guitarist on video. He is trapped forever!	139147 2000
98	A3P3QBF RD6LR3L	07390 40375	This video guitar lesson is for those who want to get a bit more technical into their repertoire. Intense Rock 1 has old school Paul (good old Racer X days) teaching us the basics of soloing, scaling and just good guitar playing overall. I like how he also incorporates funny skits in between sessions which is great cos learning guitar is meant to be a fun experience too (in his case anyways). Intense Rock 2 kinda builds on the first, introducing a few more patterns and sequences. Paul continues his humorous presentation keeping the audience awake and laughing. I play with a whammy bar so it's a bit of a shame PG doesn't like it too much but that's his playing style I guess.Overall PG is a cool and fun down-to-Earth guitar teacher you won't be disappointed. Oh and did I mention he's the world's 4th fastest guitar player?	125850 2400
99	APR59BM JNHKHX	07390 40375	Paul Gilbert instructs viewers in his style of incredibly fast guitar playing while entertaining you with "guitar tricks" and Cheerleader segways. A must buy for anyone who wants to learn speed picking techniques with a sense of humor.	117858 2400
100	ALKPRBP 7WIUE2	07390 40375	I've worn out this video over the years cause I got it on VHS,now its on DVD! My few comments on Paul Gilbert is that through his playing,he show's alot of discipline and passion on the way he play's. but most of all, he's passionate about music thats why he got to the level of where he's at. I've meet him couple of times at a NAMM show and it was like talking to the next door neighbor. no rocks star attitude just plain Paul Gilbert DOWN TO EARTH...If your like me who's alway's practicing to get better all the time and to learn more, GET THIS DVD and apply the skills you learn from Paul in a band situation when its called for. I happen to be fortunate that growin up in the 80's doing this stuff called shred playing was the NORM back then, so I caught up to this GIT style real quick and for the most part,this was the ticket to be in a band back then.if you've never done this kinda stuff then be prepared for some serious learning curve adjustments. Dont give up keep up on practicing and discipline,some things dont come easy but when you get there, its personaly an awesome accomplishment,convidence builder. but most of all one's you can master 2 or 3 of Paul's licks it comes easier cause it builds on top of each other. happy picking and have some good laughter on Paul's humor...	118316 1600
101	A1GK60U C3GWN0 V	07390 42726	Yes indeed, an absolute shocker. I expected a lot from this DVD. A great disappointment. The playing is great but hardly any lessons in it. I really expected a lot but pardon me for my expression, "I regret buying this DVD."	120787 2000

id	reviewerID	asin	Content	unix Review Time
102	AD03OHH ZYU1P8	07390 42726	Very dissapointed with this product, it says 2007 and the picture shows Victor Wooten as he is today, but the dvd is a really old kind of 80's dvd,where he has a moustache and funny colours. I really thought this was a new dvd, so when i figured out what it was i was very dissapointed and mad. They sell it as gold, i could have buy it here in mexico for 2 bucks.	120061 4400
103	A1KTZAV OBUV6R V	07390 42726	I've bought quite a few videos of bass tutorials and have been playing for a few years. I'm an active musician as well, and I found very little redeeming about this video. The playing is fantastic, don't get me wrong, he's a modern legend. However, his lessons are really far too short. The double thumb technique is never articulated at an angle from which the viewer can easily learn it, and I've turned to watching the Montreal Bass Day '98 to try and get a better view of it. He doesn't offer very much in the way of playing technique or soloing, which completely irritated me given the title. I wish I could have previewed this video before I watched it, because to me it wasn't worth the thirty dollars for a live concert DVD.	119180 1600
104	A2OV9NK 57AXE41	07390 42726	Its definately a great dvd, but I was expecting it to contain recorded footage that was mostly new. The actual dvd is old (but dont get me wrong, he still rocks out) but has some new footage of him playing a few concerts. Its a good buy for motivation, and transcription ideas, if your an advanced player. And if your a beginner, the lessons will definately help.	118756 8000
105	A1WHGN U87BGJ2S	07390 42726	This is listed as 2007 but its more like 1993 based on an internet search and the fashion on the video. There are some interesting concepts here. He discusses a basic right hand concept (double thumb, tapping) and then gives the background for it, ideas to take it further on your own and a song to illustrate the concept in action. A complete package. Now with that good stuff said this video is short on instructional material. Once you pull all the performances out (which are there to illustrate points but we will anyway) there is about 15 mins of instruction in here tops. I would say that if you're just getting into bass (under six months), want to have fun and get out of two finger right hand playing then this video will show you some ways to do it. If you're an intermediate player there might be some interesting nuggets here if you stay open to receiving them. If you're an advanced student then you should skip this.	134637 1200
106	A10N1FI7 NPVQJN	07390 45032	Very interesting for all JLL fans; shows some live footage, but also demonstrates JLL's style of piano playing and gives some insight into his career/family stories, told by JLL/his sister/daughter/and buddies. Recorded approx. 2006/2007	123249 6000
107	A1FKAW A271ZFA9	07390 45032	For music, Jerry Lee can't be beat and his piano touch is excellent and no one can take care of a melody like him. He is Beethoven in the type of music he does. If you like music he can't be beat. If to you music is noise, look for a guitar player. Carl	120363 8400
108	A25HDY6 S35439C	07390 45032	Jerry Lee tells it like it is here. Also you can see the position of his hands on the piano keyboard, so if you are inclined to copy his style of playing, you may do that.	137004 4800
110	AYE270R	07390	I was extremely disappointed in this DVD. It's 99% Jerry Lee talking to his sister and maybe 1% Jerry Lee playing piano. I only	119836

id	reviewerID	asin	Content	unix Review Time
	4ZVBKJ	45032	gave it one star because I wasn't allowed to give it zero. Pass on this one folks!Jim B	8000
111	ADN2SQ5 BPQ9MD	07390 45032	This is going to be very biased because Jerry Lee Lewis and his sister, who interviews him in this DVD, are friends of mine for many years. This is an excellent interview and very intimate discussion in which Jerry opens up and tells about his start and shows how he plays. The camera angles give keyboard enthusiasts a view of his hands never seen before. The DVD extras include print-outs of music sheets. Well worth any piano player's while to own this and definitely belongs in the collection of EVERY Jerry Lee Lewis fan, and rock and roll lover.Kay Martin, Brooklyn, NY	119784 9600
112	AN2GJQX MYGU0G	07390 45032	If you are a true Jerry Lee Lewis fan you will love this. It is an interview format with performances included. If you're not a real fan you might find this boring.	120510 7200
113	A1VQLNF EO9X2L3	07390 45032	i love gerry, no one like him but i find it sad to see him looking older even though we know he is, keep on trucking gerry	137557 4400
114	A1JFWQ7 Y7FWTJ2	07390 45032	Well recorded, It's a great video to learn the music end tecnics directly from The Killer himself.Also works as a entertainment.Shake It Baby!	125288 6400
115	A2904JG0 M9BZCA	07390 45032	Good personalized story of The Killer told by himself. I would have liked to see some other songs performed like Crazy Arms, but it was still entertaining and educational.	129288 9600
116	A218OJVC ZTFHTK	07390 45032	finally the killer teaches you how to play like him!great interviews great concert GREAT DVDextra printable piano sheet music	121789 4400
117	ADTYAV SEXP7Z	07390 45067	I was wondering if this dvd was any good, because it was so old but the lessons on this dvd are never ending. I have a lot of instructional dvds some are great some are just ok this dvd is great. if you want to learn how to improvise jazz fusion or just jazz period this is the dvd for you. Scott Henderson lets it all out of the bag on his ideas about improve.Buy it Buy it Buy it.	137160 0000
118	A184CH5 UFTQFG4	07390 45067	The first part of the dvd featuring `Screech` from t.v`s `saved by the bell` is the best part but the second part featuring `Side show bob` from `The simpsons` is quite painful to watch because of the facial expressions!	133876 8000
119	A3VBXK KUEP18U C	07390 45067	I had this on two vhs tapes. The dvd is clear,easier to scroll through. This is a great breakdown of soloing choices that gives ideas and insight that will take years to master! As with all instructional material i take a piece of it and work on it and at a future time refer back and get more ideas. I recommend this dvd to any serious guitarist who wants to expand their knowledge and vocabulary or break out of a rut. Also, this has great insight on "outside" playing.	134827 2000
120	A288JYX XGQ8VG4	07390 45067	Everything you need to know is right there.A fantastic musician who can teach.A must for all level guitarists who want to improve.So recommended.	140158 0800

id	reviewerID	asin	Content	unix Review Time
121	A38OQW8 G1IV1IJ	07390 45067	A bit about me - B.M. Berklee Col. Of Music, studied with Gary Burton, Mike Stern, Jeff Berlin, Bob Berg etc. Lots of gigs and then an MBA to pay the bills. Does this mean I know what I'm talking about - no. But, it means I've heard a bunch both good and bad. Yes, the synth tone is God awful and the production values are sub-terrain an but this is the single best DVD to help you navigate `jazz` changes. Mr. Henderson revels how scales relate to chords in a systematic and though manner that will give the tools to unlock your ability to play modern chord progressions. The section of the DVD devoted to phrasing is brilliant - a must have if you want to avoid the stream of eights-notes saying nothing that is so easy to fall into. It will take some studying on your part and good deal of sheading before you can make this material `yours` but it is such a valuable tool I cannot imagine a cheaper and easier way to get from point A to B.	133289 2800
122	A1ATI1K KSPJM8H	07390 45067	This is two instructional videos in one.Instructional Video One:Scott Henderson comes form a school of playing that may not be for everyone, but his concepts are solid and musical. Most of what he teaches here is how to use scales and triads that are harmonic relatives of a parent key center to achieve "outside playing"... run this triad or that scale up or down a given interval from the root to achieve a complex sound. (an E min7b5 arpeggio over a C maj chord for example). Scott will give you a wealth of knowledge like this. So, if you are up for this way of thinking, perhaps a newbie to it, be prepared to widen your musical horizons substantially. My playing definitely benefits from this way of learning. I like taking discrete doodads, a scale or triad I already know and learning to use it in a new way to achieve a level dissonance by adding altered notes that weave in and out of the tonality. With many of Scott`s examples, I've already learned the basic scale or arpeggio, shed the geometric pattern and have them under my fingers. So, learning a new place to use what I already know is big fun. Mick Goodrick once said "its not how many chords you know, it how many uses you have for the chords you know. That holds true for all your musical phrases, patterns and licks.I think it may be obvious, but this is not a beginner`s lesson. He is not going to talk much about playing the D dorian scale over a D minor seventh chord or G mixolydian over G dominant chords. That sort of homework is a prerequisite to this DVD. But if you feel like you are looking to spice up your jazz/rock playing with this methodology, look no further. There is a lot here.Scott is not the only one who thinks this way. Emily Remler almost always utilized melodic minor scales over dominant chords as seen inEmily Remler: Advanced Jazz & Latin Improvisationand the booksJazz Guitar Structures,Pentatonic KhanceptsandIntervalic Improvisationall overlap the information given here a bit.The only issue I take with this DVD is with the synth and guitar tones Scott uses. There are dated, cheesy synth tones that are terrible and warbled percussive chorus on his guitar. His drum machine sounds rinky-dink too. That being said, use that as motivation to internalize the content of this DVD. Scott is a killer player and this DVD will show you how he does it. The role of a teacher is to eliminate your need for them. Channel that as motivation. I have no idea why he didn`t have another guitarist, off camera, simply lay down grooves for him, use prerecorded tracks or better effects, but it is what it is. Sonically, it could be much better, but not a deal breaker. Take his concepts, make them your own and play them with your rig.As for school of	132157 4400

id	reviewerID	asin	Content	unix Review Time
			thought, Joe Pass and Jimmy Bruno don't think this way at all. Vic Juris jokes that you can't be drunk and think like this. Pat Martino has his own way of thinking based off diminished scales (because they are always symmetrical on the guitar) and whatever Holdsworth is doing, even he can't explain. Instructional Video Two: I'm going to be brief on this one. This video has some cool licks and Scott's playing is great (when he doesn't kick in the synth guitar), but there's a pretty big disadvantage to attempting to learn how to phrase lines from prerecorded video instruction (as opposed to a live teacher). Simply put, you can't receive instant feedback and focus on your weaknesses. Scott says all the right things, don't ramble, put rests between your phrases, motivically develop your lines, play musically and so on. These concepts are IMHO best learned during live private instruction.	
123	A1ZMV5Q SAR8V2L	07390 45067	scott Henderson is a jazz/fusion guitarist with excellent skills! there's a lot to learn from this video, so take your time and try to get all you can from it, it will surely help any guitarists skills at any level!!!!	138075 8400
124	AN2DZ77 G8HXVN	07390 45067	I'm a professional touring guitarist as well as a clinician, and this video is loaded with information for the guitarist who is ready to work. Scott is a good teacher and assumes that you have a basic knowledge of modes and jazz chords. He digs deep into applications of scales over different types of chords: some modal ideas and some pentatonic uses that take you outside the key centers. This is a DVD to watch over and over, and I imagine that the learning will continue over many viewings. As I find with most videos, if you learn only one useful thing from it, it is an incredible value. This is essentially a series of lessons offering an in depth education on scale use over chords.	119741 7600
125	A2ATV6R 1A6N4FG	07390 45067	This is a compilation of his two vhs tapes. The Jazz Fusion Improvisation section covers all the scales, arpeggios, triads, outside playing, etc, you could ask for. Melodic Phrasing is a real gem. Scott does an amazing job at teaching phrasing. This DVD is about improvisation and making musical statements not just learning the top 50 guitar licks. In my ears Scott is the best improvising guitarist on the scene today.	123508 8000
126	A1SR98O TQ3EHG6	07390 45067	I have been waiting for someone to put this out in dvd form. This is a complete guitarists guide to some of Henderson's insights on what to play over what chords inside the tonal center of the chord and outside of it as well. He's one of the best in phrasing and he gives you some very useful insight to that also. This video helped me a long time ago and now that it's on dvd, it is helping me again. Henderson is one of the true masters of his instrument.	118791 3600
127	A3RFCOY B11OMGH	07390 45067	First let me state that this is the first time that I have been moved to the point of entering a review on an Amazon.com purchase, and I have made many, many purchases. What motivated me to make my first review is the horrific and abysmal quality of this "instructional" guitar playing dvd. This dvd is a joke, and the joke will be on you if you buy it. Out of the entire running time of this dvd, there is not even ten seconds of informative or enjoyable viewing or hearing time. All while I was watching this dvd, all I could think of was how I had been had. While I was watching this pathetic excuse for a jazz guitar instructional dvd, I	123793 9200

id	reviewerID	asin	Content	unix Review Time
			<p>kept saying to myself over and over "this is horrible"; In fact the dvd was so bad, it moved me to keep watching it in absolute and stunned amazement that someone would have the unmitigated gall to put it on the market for sale. As soon as I heard the first two effects laden notes, I knew I was in for a bumpy ride and a full frontal auditory assault from the stylings of Mr. Scott Henderson. Assuming that you would like to play guitar like Mr. Henderson (which I can not think of any earthly reason why you would want to), he doesn't even do a good job of teaching you to do that. He repeatedly lapses into mindless extended exercises where he appears to feel that his main job is to entertain you with his style of guitar playing, as opposed to teaching you anything. I think that this is a merciful thing. Heaven forbid that this pathetic excuse for music be propagated in any form or fashion. A better title for this dvd would have been "Scott Henderson, Live at the Video Recording Studio";.If I had read the other one star review of this product, I never would have bought the dvd. That review sums up this dvd perfectly. In jazz guitar playing, there is such a thing as "taste"; and "economy of notes"; playing. Mr. Henderson employs neither of these elements of jazz guitar playing. I beg you not to waste your money on this hoax of a dvd. Words literally fail me to tell you just how bad this dvd is. On many, many occasions I have looked at guitar players and longed to be able to play like them. In this case, I hope I never ever sound like this guy. The only possible function that this dvd could possibly serve is that if you just started playing a few months ago, this dvd will show you just just how far you have come and that you are better than you think. The dvd will be a real confidence booster for you and it will let you know that you are on the right track and he isn't.All of the other dvd purchases that I have made that I didn't particularly care for have been put on a shelf and I just don't watch them anymore. This dvd is so bad, I can't stand the thought of it being on my shelf and I have relegated it to its rightful place, the circular file.If you can watch this dvd and enjoy it, it does not bode well for your future as a quality guitar player.</p>	
128	A1XA21M FXD94SM	07390 45067	Scott Henderson is a great teacher, gives you a ton of stuff that you can use to improvise over chord changes.	140227 2000
129	A28CIW5 HG2YFA8	07390 45067	<p>First I'd like to say I'm a Professional Guitarist 24/7 and have been Playing 35+ years and I have a Music DVD & Book Library that could Rival Amazons. This video is "Garbage";. I'd even go as far to say this should be the "Poster DVD"; for "Don't Let This Happen To Your Playing";. It's basically Scott Henderson Droning a note on a "Synth Guitar"; which sounds terrible, and then playing every scale and arpeggio over it, just drifting from mode, to mode, to mode, to mode ...etc. In the 2 hours of watching this video, there's not even "One"; memorable riff.This is purely "Cerebral"; Scales (I won't even call it music). This DVD will teach you how to be great "Musicologist";, but "Not"; how to be a great "Musician";. If you want to learn this type of stuff check out "Jimmy Bruno's No Nonsense Jazz Guitar"; DVD. Jimmy Bruno gives you "Six Scales"; that cover all the modes and uses them in an extremely musical way. `Nuff said!</p>	122523 8400

id	reviewerID	asin	Content	unix Review Time
130	A15STV0 U0MEAS0	07390 46500	This DVD is very informative, and has alot of easy-to-understand technique to save your vocal chords!I recommend this to any screamer/growler at any level, beginner to advanced.Following the instructions in this DVD, I have been growling safely for days... Although i haven't quite figured out how to Scream yet, I wasn't able to extract that much from the DVD as of yet.A good DVD!	120337 9200
131	A18BD98S U49UB7	07390 46500	Melissa Cross has just broken a new boundary that is over a decade in the making: Rage 101.Her motivations seem sincere. Her intentions are to teach the up and coming youth, and in some cases established singers, how to sing raging/screaming vocals without shredding their vocal chords. Thats always good. Friends have asked for years how vocalists scream for three hours a night, a couple hundred times a year, and still have enough voice remaining to order a pizza on friday. Well, here`s the answer.Melissa has spanned her advice and techniques over two discs, and cover every aspect of the artform. Art? Yes. For those of you scratching your heads, Emotional (Emo) Hardcore with its stark contrasts of harsh realities and sweet essences creates some of the most moving bits of music you`ll ever hear. As Melissa points out, a great scream is one which covers every frequency in the spectrum, from thrashing highs to rumbling lows, all coherant.Many associate "screaming" vocals with untalented hipsters cowling in their mothers basement, churning out pointless discs of noise. Not true my friend. Here are a few discs you should check out: "Skillet: Collide" "Emery: the weaks end" "Slipknot: Volume 3." and any System of a Down disk. There are literally thousands of examples out there. These vocals are sometimes scattered throughout the music world, even in places where they wouldn't be expected. Maybe you know a few? On the same note, there are those who have other preferences in music, thats fine too. To each his own.The Zen of Screaming is a tool for the future generation who pour their feelings upon scattered papers, bursting their internal furies of love, life and experiences into the ears of willing listners.(PS - Huge thanks to Melissa Cross on her feedback for my review. Hope things continue to flourish for you!)	112959 3600
132	A3AKPZ2 LVRP0LG	07390 46500	i was a bit supriised to find that there wasnt much info on actually screaming on the dvd, until i figured out that all the breath control and positioning of the voice IS how you scream, overall this is the best vocal instructional dvd i have come accross. and the cd that comes with it for the warmup is invaluable!!buy this dvd!	119508 4800
133	AT4S8BO QRJOPH	07390 46500	I've had ZoS for a couple years, but only now got around to viewing it. I actually found out about it because I purchased Jamie Vendera`s book `Raise Your Voice`. Here are a couple of notes:1) A lot of bands promoting her teaching. I already bought the book, so I`m unsure what all of this was included for. While there were a couple moments where a vocalist helped me realize something, it was mostly useless promotion.2) There`s next to nothing about actual screaming.3) There`s good info about breathing (keeping floating ribs out, taking quick breaths, etc) and the whole `Dump` thing for singing with volume, but there was nothing about singing with grit like Roger Daltrey or some headbanger group. She didn`t give any advice on using those techniques either... I feel like she should have mentioned that when you push with your stomach for the Dump, making sure your neck doesn`t get tight... someone might hurt	127638 7200

id	reviewerID	asin	Content	unix Review Time
			themselves since info was left out. So, here's the deal. I'm giving it 3 stars because I feel like a lot of this information has been covered by Singing Success and Raise Your Voice, but I still feel like some of the information might give a student an epiphany. For \$20, this very well might be worth it to someone because it might break a mental ceiling that they currently have. RYV is a book, so it has limitations. Singing Success has tons of great audio samples and good explanations. Buy these 3 items and find a friendly voice instructor on Craigslist and you will make tons of progress as long as you actually practice, otherwise you will have wasted a lot of money.	
134	A2UDUFO 37ZJBU8	07390 46500	For most metal singers taking singing lessons is not an option; first of all, nobody likes to teach how to rip your vocal cords and second, the majority of the teachers just don't get extreme metal. Melissa Cross is an amazing teacher, she is the only one teaching you this in terms that you can actually understand, with simple examples that you can do to improve your performance. She made me understand for the first time what the hell is my diaphragm, how I can control it and how I can use it to improve my breathing. Still... I was expecting a little more teaching. I felt like I was watching an infomercial for a product that I already bought. Most of the DVD is about musicians telling you how cool Melissa is and how much they've improved since taking lessons with her... but if you bought this you already knew that. I felt like buying a movie and all I see is people telling you how great this movie is, instead of showing you the movie. The teaching and exercises in this DVD are a very small percentage of the content but very effective. It is a great product if you want to learn to sing, it has easy to understand terms and great breathing exercises, but is not very good if you want to learn to scream or growl. If you want that you will have to buy the SCREAM EXTRA CD for another 20 dollars. All and all I have to give this product 4 stars because of its uniqueness. I just missed it didn't teach more screaming.	117331 2000
135	A6FNP598 ZD9NT	07390 46500	I heard Melissa Cross on NPR and immediately bought this DVD, excited to learn how to scream without hurting my voice. I was disappointed to find the disk is about 55% advertisement for Ms. Cross, 44.5% standard vocal warmups and exercises, and 1 or 2 minutes of vague information on screaming. I'm sure the vocal warmups are helpful for those who are too "hip" to take voice lessons, but if you've ever had a voice lesson, there isn't much you haven't heard before here. If you are interested in watching various metalheads praise Melissa Cross, then you'll love this DVD. But if you already have the least bit of vocal training and just want to learn how to apply it to screaming, be aware that the material here is pretty thin.	119370 2400
136	A15DP79 HGPRBC D	07390 46500	Very good tips for vocal warm-ups and how to protect your voice, but they don't even mention the word screaming until like an hour into the video... also, I felt like a lot of it was like advertising for Melissa Cross, rather than instruction (i.e. videos of band saying "oh Melissa is the greatest!!"), but overall it was helpful and I would recommend it	122549 7600
137	A288G8U ECOXTW K	07390 46500	Most of this DVD is nothing but breathing techniques and warm-up exercises. If you already know how to sing, nothing new is covered here. The reason I bought this DVD was to learn how to scream and growl properly, which hardly isn't covered at all (2-3 minutes), and	134023 6800

id	reviewerID	asin	Content	unix Review Time
			what`s there is really poor. In addition there is far too much footage of Melissas students praising her, so that it almost seems like nothing but a commercial for her lessons.	
138	A238CHH ZM54BKR	07390 46500	i am a solo artist trying to form my own band so i can start playing my songs live. i bought this dvd so i could start preparing my voice for live shows, and thats exactly what its good for. some of the past reviews i`ve read mention that there`s too much footage of bands mentioning how great melissa cross is. i will sadly agree, but still even with this problem, i learned things that will benefit me and keep my voice in good shape. keep in mind, if you dont know how to scream, and you want to learn, its something that takes time and practice. this dvd is mainly to help strengthen your singing before getting into the heavier stuff, which is what i`m sure she`ll cover in her next dvd.	116838 7200
139	AFFOIRB ORB9ED	07390 46500	This is a great tool for protecting your voice. I`ve had tons of throat problems over the years and this DVD has really helped me be able to find my voice again - without pain! The only drawback is that as you watch the DVD over again to get the instruction you have to keep watching the other guys give their opinions and experiences on the method. I wish it were cut or tracked so that you could just skip to the next bit of information without wading thru the commentary. But otherwise it`s a valuable tool. Thanks, Melissa!	118056 9600
140	A318N7N GQ6VU10	07390 46500	According to Melissa Cross`s website [...], this DVD is intended to teach the foundations for `screaming`. There is a second DVD available that teaches `screaming` more in-depth (The Zen of Screaming 2), but this DVD is not currently available on the Amazon.com website. It can only be purchased on her website as of right now.	118169 2800
141	A5SY2K6 KAX7WM	07390 46500	A great teacher is a rare find and Melissa Cross is a gem. I have read almost every vocal technique book available and The Zen of Screaming DVD is by far the best! I had given up on being able to sing with a healthy voice until I watched this DVD. I feel like I have been given my voice back. Somehow, Melissa gives the viewer years worth of vocal lessons in a little over 2 hours. Although many of the artists on this DVD scream/sing heavily, you don`t have to be a death metal singer to appreciate the information. This DVD is for anyone who wants to sing with passion, no matter the genre. Melissa breaks down the information in such a way that anyone, beginner or classically trained, can understand the basic techniques that help to make a passionate but healthy voice. This DVD is also great for anyone who speaks for their profession. It will teach you how to have a powerful voice without vocal damage. I have bought numerous items from Amazon.com, but have never felt passionately enough about them to post a review. Don`t wait another minute to hit the "buy" button.	113866 5600
142	A346X3R ARR2EW A	07390 46500	Well, first of all, I am the lead singer for my band. I am a very good singer, I`ve had many singing lessons and am in choir. I know how to sing from my diaphragm and sing with the correct vowel sounds, have good vibrato, and falsetto. BUT!! I wanted to learn how to SCREAM. I have done a few shows with a hardcore band and screamed for them and just devastated my throat. I wanted to learn how to SCREAM correctly and this dvd will not teach you how to	117478 0800

id	reviewerID	asin	Content	unix Review Time
			SCREAM. It may say it does, but it does not. Pretty much the first hour of stuff was stuff I already knew about singing. She mentions how to make your voice scratchy in about 3-4 sentences and THATS IT. I need further explanation. I am extremely extremely angry because I just wasted my money on a crappy factless infomercial for Melissa Cross. This dvd sucks!	
143	AJWUMO WLTU43V	07390 46500	I have taught voice for more than 30 years. I bought the video to see what I could do for my non-classical students. I found the technique to be sound--based on real anatomy and physiology. I have a few small disagreements but nothing that would injure a voice--that is supreme.	116856 0000
144	A8UGJVH DYSZY6	07390 46500	I liked the DVD. It helped me learn to breath properly, that was the biggest thing. I was some what dissapointed because I was hoping it would focus a lot more on screaming and aggressive singing. And I didnt much like all the band interviews through out the whole DVD. But overall, I would definently recommend it, because it does help.	115456 3200
145	A151WED 01PRU7E	07390 46500	I used to feel a scratching in the back of my throat if I sang for more than half an hour, and a full hour of singing at proper volume sometimes caused my voice to wear out completely.Since watching The Zen of Screaming and doing the included vocal exercises before every rehearsal and every show, I can now sing SO much better, at full strength for at least 5 hours. My range has improved, my tone has improved, and most importantly, my confidence has improved.The CD of vocal exercises can be loaded onto your iPod so that you can quickly do them on the run to the gig!Melissa makes it fun, with terms you can visualize and remember easily. I rave about this DVD to every musician & spoken word performer I know. I'm sure I've become annoying! But it WORKS!!!	124917 1200
146	A3HFJZ4R 1L1U8T	07390 46500	I purchased this item for my son`s birthday. It indicated that it was a brand new item. When we opened the package, the DVD was scratched and it appeared used. I did not bother to follow up with the seller. I'm not ordering from them again. That`s deceiving to advertise an item as brand new, wrap it nice and neatly to sell-- when opened it was very obvious that this was a used item. Not sure how they can get away with doing that. When my son watches the DVD, there are parts of it that freezes up. Horrible product and advertisement. I wouldn't recommend ordering from them since there is no way to know if they are telling the truth about their products being new. Sad thing is that my son wants to get other screaming dvd...if I decide to get it, I won't purchase from this seller.	132658 5600
147	A6PKIM7 96BFFK	07390 46500	wanna sing like a madman (or madwoman) and not lose your voice? then buy this dvd. 3 hours of info on how to do the job right without tearing your voice up.	118653 1200
148	A3V6WO7 WA5AF9	07390 46500	This seems to be like any other vocal warm-up, exercise audio you can get.The DVD is an "Infomercial", it's like they were going to put it on late night tv and didn't, so thought, "what the hell, .. lets put it in the product to look like it's more than just a cd audio".The product really is just the cd audio with do-re-mi like exercises. caveat emptor.	126714 2400

id	reviewerID	asin	Content	unix Review Time
149	A3V6WO7 WA5AF9	07390 46500	I guess if you already produced an expensive infomercial that is basically paid testimony why not throw it into the package to create the illusion of, "...but wait, there`s more!" product offering. The dvd is just an infomercial of metal musicians saying how good it is. But there is no teaching. No matter how many times you watch someone tell you how good something is will never make you good! LOL! I`m waiting for the melissa cross zen of nuclear physics with a bunch of lab coats on dvd telling me how good melissa is at nuclear physics and how i`m going to learn! Keep up the "Zen of ..." franchise.. Is the second dvd an updated infomercial with death and steampunk screaming? LOL! P.O.S. waste of money.. The cd has do-rei-me exercises for the vocally challenged.. with bonus pa-pa-pa`s et al.!	126895 6800
150	A3AG84A UO48GFH	07390 46500	This is an amazing tool for any want to be screamer. It has helped me so much! The zen is a must have!	128010 2400
156	A0001528 BGUBOE VR6T5U	B0055 Q2VN I	Great. Fast, silent, big drive. I would recommend to anyone. For the price its a great buy and internally its a good drive.	136287 3600
157	A0001528 BGUBOE VR6T5U	B0055 Q2VS 8	Great. Fast, silent, big drive. I would recommend to anyone. For the price its a great buy and internally its a good drive.	136287 3600
158	A0001528 BGUBOE VR6T5U	B0058 UUR6 E	Great!	140434 5600
159	A0001528 BGUBOE VR6T5U	B005 HTH7 8W	Great!	140434 5600
160	A0001528 BGUBOE VR6T5U	B005P WV1 OW	Great!	140434 5600
161	A0001528 BGUBOE VR6T5U	B005 XU7O L0	Well what can I say. Its a dome. Water tight, nice, does what it should, protects! Its nice, well made.....etc. Buy it.	136287 3600

Daftar Stop-word

Berikut adalah daftar *stop-word* yang ada dalam kamus yang digunakan pada StopwordTool.

<i>a</i>	<i>doesn't</i>	<i>i'll</i>	<i>out</i>	<i>through</i>	<i>you</i>
<i>about</i>	<i>doing</i>	<i>i'm</i>	<i>over</i>	<i>to</i>	<i>you'd</i>
<i>above</i>	<i>don't</i>	<i>i've</i>	<i>own</i>	<i>too</i>	<i>you'll</i>
<i>after</i>	<i>down</i>	<i>if</i>	<i>same</i>	<i>under</i>	<i>you're</i>
<i>again</i>	<i>during</i>	<i>in</i>	<i>shan't</i>	<i>until</i>	<i>you've</i>
<i>against</i>	<i>each</i>	<i>into</i>	<i>she</i>	<i>up</i>	<i>your</i>
<i>all</i>	<i>few</i>	<i>is</i>	<i>she'd</i>	<i>very</i>	<i>yours</i>
<i>am</i>	<i>for</i>	<i>isn't</i>	<i>she'll</i>	<i>was</i>	<i>yourself</i>
<i>an</i>	<i>from</i>	<i>it</i>	<i>she's</i>	<i>wasn't</i>	<i>yourselves</i>
<i>and</i>	<i>further</i>	<i>it's</i>	<i>should</i>	<i>we</i>	
<i>any</i>	<i>had</i>	<i>its</i>	<i>shouldn't</i>	<i>we'd</i>	
<i>are</i>	<i>hadn't</i>	<i>itself</i>	<i>so</i>	<i>we'll</i>	
<i>aren't</i>	<i>has</i>	<i>let's</i>	<i>some</i>	<i>we're</i>	
<i>as</i>	<i>hasn't</i>	<i>me</i>	<i>such</i>	<i>we've</i>	
<i>at</i>	<i>have</i>	<i>more</i>	<i>than</i>	<i>were</i>	
<i>be</i>	<i>haven't</i>	<i>most</i>	<i>that</i>	<i>weren't</i>	
<i>because</i>	<i>having</i>	<i>mustn't</i>	<i>that's</i>	<i>what</i>	
<i>been</i>	<i>he</i>	<i>my</i>	<i>the</i>	<i>what's</i>	
<i>before</i>	<i>he'd</i>	<i>myself</i>	<i>their</i>	<i>when</i>	
<i>being</i>	<i>he'll</i>	<i>no</i>	<i>theirs</i>	<i>when's</i>	
<i>below</i>	<i>he's</i>	<i>nor</i>	<i>them</i>	<i>where</i>	
<i>between</i>	<i>her</i>	<i>not</i>	<i>themselves</i>	<i>where's</i>	
<i>both</i>	<i>here</i>	<i>of</i>	<i>then</i>	<i>which</i>	
<i>but</i>	<i>here's</i>	<i>off</i>	<i>there</i>	<i>while</i>	
<i>by</i>	<i>hers</i>	<i>on</i>	<i>there's</i>	<i>who</i>	
<i>can't</i>	<i>herself</i>	<i>once</i>	<i>these</i>	<i>who's</i>	
<i>cannot</i>	<i>him</i>	<i>only</i>	<i>they</i>	<i>whom</i>	
<i>could</i>	<i>himself</i>	<i>or</i>	<i>they'd</i>	<i>why</i>	
<i>couldn't</i>	<i>his</i>	<i>other</i>	<i>they'll</i>	<i>why's</i>	
<i>did</i>	<i>how</i>	<i>ought</i>	<i>they're</i>	<i>with</i>	
<i>didn't</i>	<i>how's</i>	<i>our</i>	<i>they've</i>	<i>won't</i>	
<i>do</i>	<i>i</i>	<i>ours</i>	<i>this</i>	<i>would</i>	
<i>does</i>	<i>i'd</i>	<i>ourselves</i>	<i>those</i>	<i>wouldn't</i>	