

Auto Machine Design Hot Stamping Unit and Analysis of the use of Hot Stamping on Materials

Dewa Kurnia Sandy¹, Irwanto Zarma Putra¹, Diono¹, Abdurahman Dwijotomo¹, and Eka Mutia Lubis^{1*}

¹Jurusan Teknik Elektro, Politeknik Negeri Batam, Batam, Indonesia

*Email: irwanto@polibatam.ac.id

Abstract—as the years go by, there are many innovative developments in various fields, including the health sector, especially in medical devices themselves. One of the conditions for medical equipment to be used is to look at the condition of the equipment, its suitability for use, sterilization and standardization of the equipment. If the condition of a medical device does not meet the requirements, then the use of the device is certainly not recommended. Because this will have a negative impact on the medical process. Therefore, this research will create a machine that can carry out the stamping or marking process in the production process of transfusion set equipment. The purpose of marking the transfusion set device is to mark the locking direction of the device itself, which will make it easier for medical personnel to carry out medical procedures. The method used in this research is to apply the principle of a pneumatic drive system and PLC as a control system for this tool. Apart from that, the design of this tool also aims to determine the impact of using Hot Stamping on materials made from PVC plastic, and analysis of the results of the process can be carried out. In this research, the analysis process carried out on the set transfusion hose will use the Quantitative Descriptive analysis method on the stamping temperature, then the data from the results of this analysis will be used to determine the optimum temperature value and stamping duration that should be used for the stamping process in the production process.

Keyword: Medical Devices, Pneumatic Systems, PLC, Rotary Encoder.

I. INTRODUCTION

Transfusion set is one of the most important medical equipment used in the blood transfusion process, in the blood transfusion process there are standards that must be considered when carrying out the process, including the standards on the Transfusion set itself. One of the eligibility standards on the transfusion set is the presence of a line mark on the end of the transfusion set hose, the mark is a black line that indicates the direction of the tip of the needle and the transfusion set hose lock. This is important for medical personnel to note when carrying out medical procedures, especially in medical

procedures that use the transfusion set itself.

Therefore, in this study, a machine will be created that can perform a marking process or marking on the Transfusion set tool. There are several methods that will be used in this study, namely the pneumatic system, PLC and rotary encoder. The three methods will be applied together, so that it will become a machine that will perform the hot stamping process on the Transfusion Tube.

The basis of the design of this Auto hot stamping Machine is that initially the marking process on the transfusion set hose was carried out manually using a marker and a limiting jig as a printing media tool for marking on the transfusion set hose, after the marking process was carried out, the transfusion tool would be continued with a dryer process or drying process on the marking ink that had been printed on the transfusion set hose, however, this process caused many rejects in the marking section due to the use of unstable marker ink in the marking process.

So from these problems a machine is designed that can perform the Hot Stamping process as a replacement for the marking process using marker ink. Hot stamping is a dry printing process where color pigments or metal materials are transferred from a sheet of film paper continuously to the object to be decorated. This application is controlled by heat and pressure, this process is clean, dry and fast, and free from the problems generally associated with the wet ink printing process.

II. METODE

number of pages. Use italics for emphasis; do not underline. Moving components include blacktape roller drive motor, tube cutting roller drive motor, stamping cylinder and grip cylinder. And the drive motor which is connected to the roller tube cutting section uses the Rotary Encoder braking method as a motor rotation limiter so that the tube length can be adjusted, and this machine uses a PLC as a motion control system for each motion component contained in this machine.

Because a series of processes can be run on one machine simultaneously to increase efficiency. So the method used in

this research is to apply a pneumatic system, PLC and use a rotary encoder and also an Ac motor which will carry out the tube cutting process..

A. Research Flow

several stages in the process of making an Auto Hot Stamping Unit Machine. The earliest stage is to conduct a literature study that is useful to support machine manufacturing. After knowing the information about making the machine, the next stage is to design the system. When the system design already exists, it means that at this stage there is already an idea of the tools and materials that will be used in making the machine. Then there is the purchase of tools and materials, which is followed by the mechanical design stage. When the tools and materials, as well as the mechanical design already exist. Then the electrical design can be done, and programming can also be done. After these six stages have been carried out, the machine manufacturing process will be able to run according to the schedule that has been made. In fact, when one of these stages can be done quickly, the machine manufacturing process can be faster than the schedule that has been made. Next are testing stages 1 and testing 2. When both testing stages have been carried out, the machine manufacturing process is complete and can be sent to production.

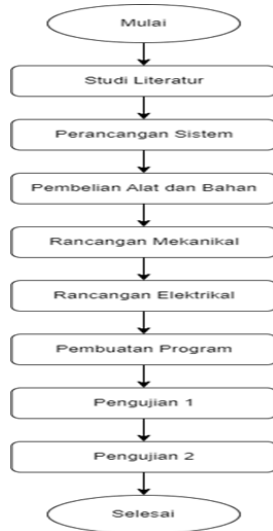

Image 1. Research Flow Image

B. Software design flow

There are several stages in designing the use of machines, namely: Starting by turning on the power switch, then continuing by opening the air valve in the regulator section, next is waiting for the temperature of the stamping mold heater to reach a value of 100°C. After the heater temperature has reached 100°C, the production process can be carried out with the first process, namely the tube and Transfusion wing assembly process carried out by operator 1, then placing the Transfusion wing into the available stamping jig. When the Transfusion wing that has been placed into the stamping jig is

correct, the sensor located under the surface of the jig will read then the stamping cylinder will automatically move down to carry out the stamping process on the Transfusion Tube and simultaneously the tube cutting roller motor will also move to carry out the process. tube supply or tube cutting. The results will be continued by operator 2 for the checking process. Then the product can be separated into product storage.

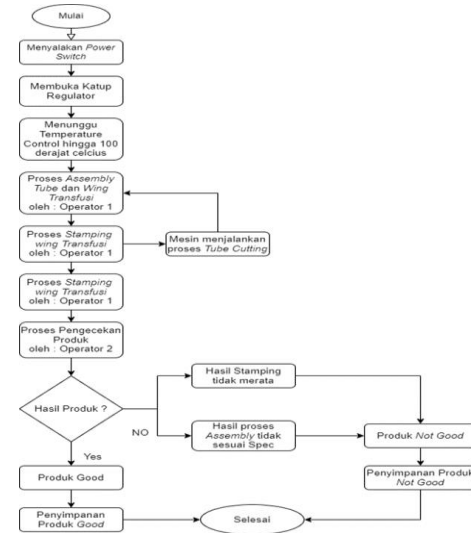

Image 2. Software Design Image

C. System design flow

The following is a system design for the assembly process for products that will be used on the Auto Hot Stamping machine

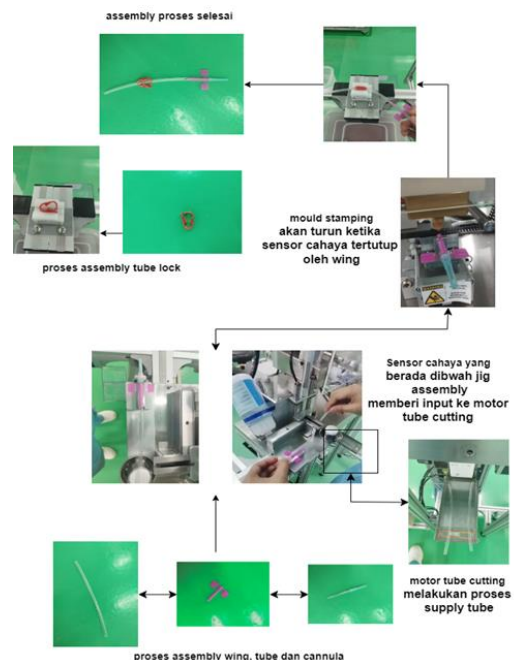

Image 3. SystemDesign Image

D. Machine Mechanical Design

The following is the design of the Auto Hot Stamping machine that will be used for the production process.

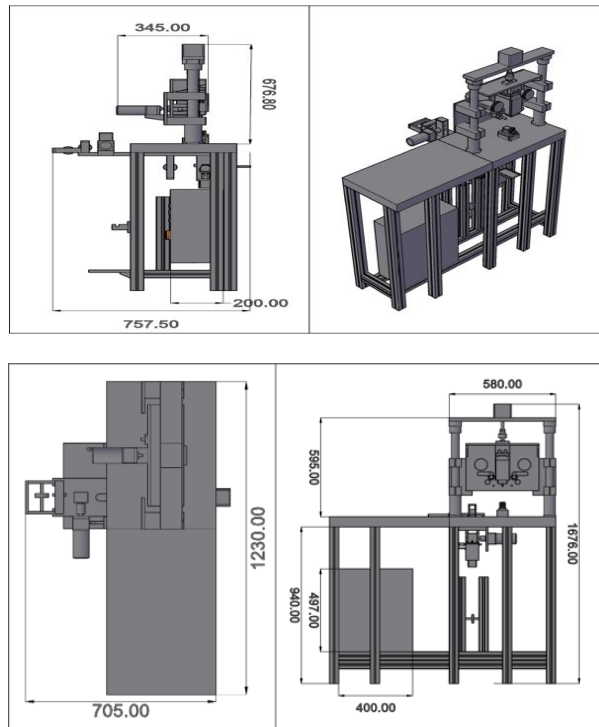

Image 3. Machine Mechanical Design Image

III. RESULTS AND DISCUSSION

A. Output and Input Test Results on the machine

The test results on this machine show that all components of the device function well. Even though the results are positive, it is important to remember that this test is carried out under controlled conditions. To implement this machine it is necessary to carry out a series of further trials taking into account variations in machine conditions. In temperature testing the results of the production process and several tests will also be carried out such as temperature determination, crack test, fastness test and mark size. Success in carrying out several tests provides confidence that the application of this machine can run effectively.

B. Temperature and Holding time testing of marking shape and Tube durability

With the results obtained from the cycle time in the previous table, Holding time has a difference in temperature to determine appropriate parameter settings that can meet quality, appearance and dimensional specifications. Therefore, testing will be carried out using eleven variable temperature parameters and 3 holding time settings. The temperature settings are 70°C, 75°C, 80°C, 85°C, 90°C, 95°C, 100°C, 105°C,

110°C, 115°C, and 120°C. for holding time settings, namely, 10 (1 second), 20 (2 seconds) and 30 (3 seconds).

Holding Time (second)	Temp (°C)	S/S	Appearance Inspection Result							Result	Judg.	
			Scratch on Wing	Scratch on Tube	Smear Stamp	Melted Tube	Poor Stamp	Mark Position on Tube	Stain/ F P on Surface			
1	70	30	0/30	0/30	0/30	0/30	17/30	0/30	4/30	21/30	Fail	
	75	30	0/30	0/30	0/30	0/30	15/30	0/30	1/30	15/30	Fail	
	80	30	0/30	0/30	0/30	0/30	15/30	0/30	0/30	15/30	Fail	
	85	30	0/30	0/30	0/30	0/30	0/30	0/30	0/30	0/30	Pass	
	90	30	0/30	0/30	0/30	0/30	0/30	0/30	0/30	0/30	Pass	
	95	30	0/30	0/30	0/30	0/30	0/30	0/30	0/30	0/30	Pass	
	100	30	0/30	0/30	0/30	0/30	0/30	0/30	0/30	0/30	Pass	
	105	30	0/30	0/30	0/30	0/30	0/30	0/30	0/30	0/30	Pass	
	110	30	0/30	0/30	0/30	0/30	0/30	0/30	0/30	0/30	Pass	
	115	30	0/30	0/30	0/30	0/30	0/30	0/30	0/30	0/30	Pass	
	120	30	0/30	0/30	0/30	0/30	0/30	0/30	0/30	0/30	Pass	
	2	70	30	0/30	0/30	0/30	0/30	15/30	0/30	2/30	17/30	Fail
75		30	0/30	0/30	0/30	0/30	15/30	0/30	1/30	15/30	Fail	
80		30	0/30	0/30	0/30	0/30	0/30	0/30	0/30	0/30	Pass	
85		30	0/30	0/30	0/30	0/30	0/30	0/30	0/30	0/30	Pass	
90		30	0/30	0/30	0/30	0/30	0/30	0/30	0/30	0/30	Pass	
95		30	0/30	0/30	0/30	0/30	0/30	0/30	0/30	0/30	Pass	
100		30	0/30	0/30	0/30	0/30	0/30	0/30	0/30	0/30	Pass	
105		30	0/30	0/30	0/30	0/30	0/30	0/30	0/30	0/30	Pass	
110		30	0/30	0/30	0/30	0/30	0/30	0/30	0/30	0/30	Pass	
115		30	0/30	0/30	0/30	0/30	0/30	0/30	0/30	0/30	Pass	
120		30	0/30	0/30	0/30	0/30	0/30	0/30	0/30	2/30	5/30	Fail
3		70	30	0/30	0/30	0/30	0/30	15/30	0/30	0/30	15/30	Fail
	75	30	0/30	0/30	0/30	0/30	15/30	0/30	1/30	15/30	Fail	
	80	30	0/30	0/30	0/30	0/30	0/30	0/30	0/30	0/30	Pass	
	85	30	0/30	0/30	0/30	0/30	0/30	0/30	0/30	0/30	Pass	
	90	30	0/30	0/30	0/30	0/30	0/30	0/30	0/30	0/30	Pass	
	95	30	0/30	0/30	0/30	0/30	0/30	0/30	0/30	0/30	Pass	
	100	30	0/30	0/30	0/30	0/30	0/30	0/30	0/30	0/30	Pass	
	105	30	0/30	0/30	0/30	0/30	0/30	0/30	0/30	0/30	Pass	
	110	30	0/30	0/30	0/30	0/30	9/30	0/30	17/30	0/30	5/30	Fail
	115	30	0/30	0/30	0/30	12/30	0/30	30/30	0/30	14/30	30/30	Fail
	120	30	0/30	0/30	0/30	12/30	0/30	30/30	0/30	15/30	30/30	Fail

Image 4. Summary of test results for determining temperature and holding time

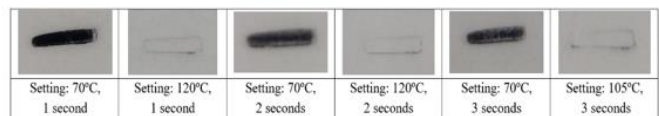
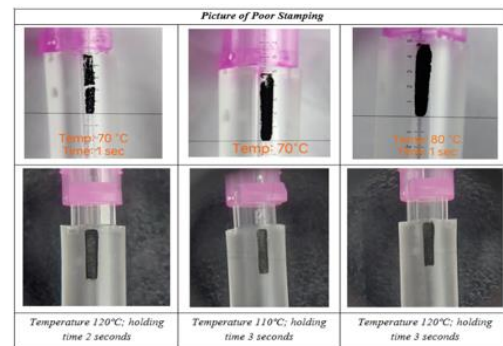

Image 4. Comparative results from testing for determining temperature and holding time

C. Fastness testing results in the production process

The results of the fastness test or fading test contained in the table above show several results that are not suitable or fail when using low temperatures in the stamping process. This is because the shape of the marks produced from the stamping process looks faded and is not printed perfectly, fastness testing The test is also carried out using cellulose tape attached to the mark/stamp on the tube, rubbed several times, then pulled quickly



Image 5. Fastness test results

D. Crack test results

Crack Test is a crack test carried out on the hub to determine whether the stamping process with a clamping chuck and stamp that is pressed for a certain time and temperature causes damage to the hub. No cracks were checked on the hub from all test setups even with a 3 second hold/stamping time.

E. Size of Mark/Stamp test

This additional dimensional check refers to the size markings on the tube which are carried out as an appearance check within the QAC inspection criteria. However, length and width measurements are taken to ensure that it meets the written size specifications. From the results above, it is known that the test temperature and holding time do not have a significant effect on the size of the marks created on the tube. The measured mark sizes for all test setups met length and width specifications with a specified range of 4.6 - 5.0mm length and 0.7 - 1.3 mm width.

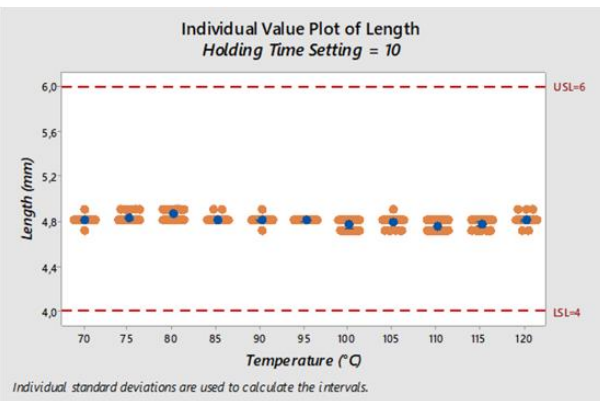
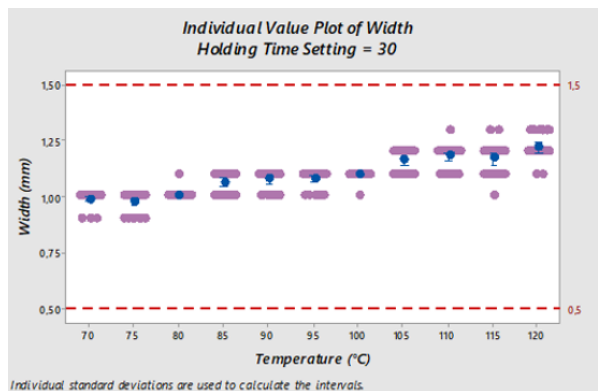
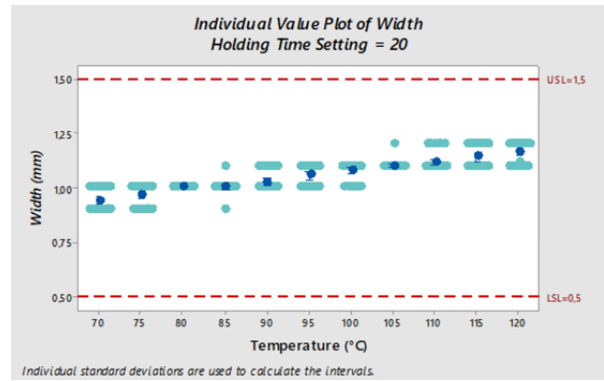
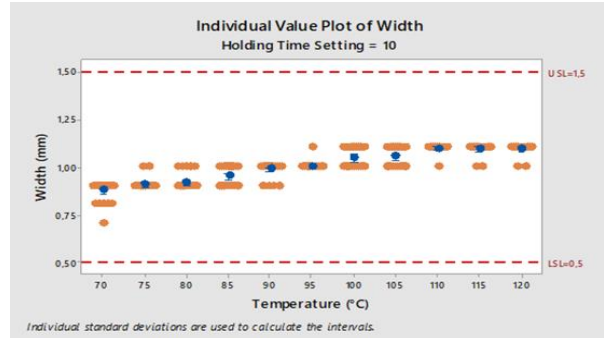
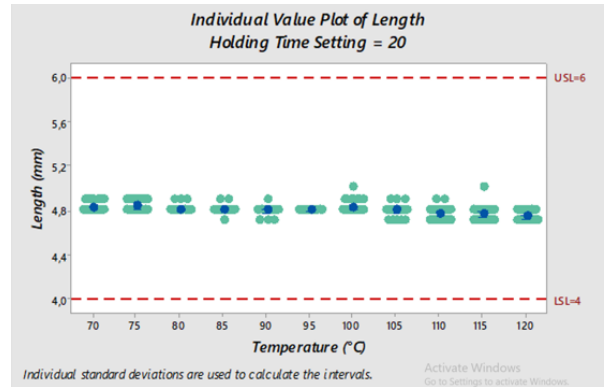

Image 6. Distribution of data from the results of testing the width of markings on product samples

Holding Time (second)	Temp (°C)	S/S	Fastness Test*	Crack Test (Spec: No crack)	Size of Marking/Stamp					
					Spec: 4 mm ≤ Length ≤ 6 mm & 0.5 mm ≤ Width ≤ 1.5 mm					
					Length of Mark (mm)		Width of Mark (mm)		Result	Judgment
Min	Max	Min	Max							
1	70	30	Fail	3030	4.7	4.9	0.7	0.9	3030	Pass
	75	30	Fail	3030	4.8	4.9	0.9	1	3030	Pass
	80	30	Fail	3030	4.8	4.9	0.9	1	3030	Pass
	85	30	Pass	3030	4.8	4.9	0.9	1	3030	Pass
	90	30	Pass	3030	4.7	4.9	0.9	1	3030	Pass
	95	30	Pass	3030	4.8	4.8	1	1.1	3030	Pass
	100	30	Pass	3030	4.7	4.8	1	1.1	3030	Pass
	105	30	Pass	3030	4.7	4.9	1	1.1	3030	Pass
	110	30	Pass	3030	4.7	4.8	1	1.1	3030	Pass
	115	30	Pass	3030	4.7	4.8	1	1.1	3030	Pass
	120	30	Pass	3030	4.7	4.9	1	1.1	3030	Pass
	2	70	30	Fail	3030	4.8	4.9	0.9	1	3030
75		30	Fail	3030	4.8	4.9	0.9	1	3030	Pass
80		30	Pass	3030	4.8	4.9	1	1	3030	Pass
85		30	Pass	3030	4.7	4.9	0.9	1.1	3030	Pass
90		30	Pass	3030	4.7	4.9	1	1.1	3030	Pass
95		30	Pass	3030	4.8	4.8	1	1.1	3030	Pass
100		30	Pass	3030	4.8	5	1	1.1	3030	Pass
105		30	Pass	3030	4.7	4.9	1.1	1.2	3030	Pass
110		30	Pass	3030	4.7	4.9	1.1	1.2	3030	Pass
115		30	Pass	3030	4.7	5	1.1	1.2	3030	Pass
120		30	Pass	3030	4.7	4.8	1.1	1.2	3030	Pass
3		70	30	Fail	3030	4.8	4.9	0.9	1	3030
	75	30	Fail	3030	4.8	4.9	0.9	1	3030	Pass
	80	30	Pass	3030	4.8	4.9	1	1.1	3030	Pass
	85	30	Pass	3030	4.8	4.8	1	1.1	3030	Pass
	90	30	Pass	3030	4.8	4.8	1	1.1	3030	Pass
	95	30	Pass	3030	4.7	4.8	1	1.1	3030	Pass
	100	30	Pass	3030	4.7	4.8	1	1.1	3030	Pass
	105	30	Pass	3030	4.7	5	1.1	1.2	3030	Pass
	110	30	Pass	3030	4.6	4.9	1.1	1.3	3030	Pass
	115	30	Pass	3030	4.8	5.2	1.1	1.3	3030	Pass
	120	30	Pass	3030	4.9	5.2	1.1	1.3	3030	Pass

Image 6. Summary of Test Results of Fastness Test, Crack Test and Size of Mark/Stamp

IV. CONCLUSION

From the design of the tool to the implementation of the Hot Stamping Unit Machine which has been carried out by the author and can be said to be complete, the process of making the machine has been in accordance with the problem formulation, objectives, benefits and limitations determined by the author. a. By using the main air pressure setting of 0.05 Mpa and using eleven variable temperature parameters and 3 holding time settings. The temperature settings are 70°C, 75°C, 80°C, 85°C, 90°C, 95°C, 100°C, 105°C, 110°C, 115°C, and 120°C. for holding time settings, namely, 10 (1 second), 20 (2 seconds) and 30 (3 seconds). The lower limit and upper limit values for product standards will be obtained. Apart from that, from the results of this test, material durability parameters are also obtained, namely by carrying out Fastness Test, Crack Test and Size of Mark/Stamp. From the results of this test it can also be concluded that the use of Hot Stamping on PVC (polyvinyl Chloride) materials can be used as part of the process.

REFERENCES

[1] MEHMET ALPER AGCA, & MUNIR TASDEMIR. (2016). INVESTIGATION OF HOT STAMPING PROCESS PARAMETERS IN UP&DOWN MACHINING ON ABS MATERIALS UNDER QUALITY PURPOSES OF DIFFERENT STAMPING PROCESSES. [accessed Ags. 1, 2023]. W.-K. Chen,

Linear Networks and Systems. Belmont, CA, USA: Wadsworth, 1993, pp. 123–135.

- [2] NOMURA, Masahiro KUBO, Hiroshi FUKUCHI, & Masahiro NAKATA. THE IMPACT OF USING HOT STAMPING ON STEEL MATERIALS. <https://www.nipponsteel.com/en/tech/report/pdf/122-05.pdf>, November 2019 [Ags. 15, 2023]. E. P. Wigner, "Theory of traveling-wave optical laser," *Phys. Rev.*, vol. 134, pp. A635–A646, Dec. 1965.
- [3] Eko Syamsuddin. (2020). Alat Pencetak Tanggal Kadaluaarsa pada Plastik Pack dengan Metode Hot Stamping. *Jurnal Teknik Elektro*, 21(2), 156. https://www.researchgate.net/publication/343883649_Alut_Pence tak_Tanggal_Kadaluaarsa_pada_Plastik_Pack_dengan_Metode_H ot_Stamping
- [4] Astrans, "Apa yang dimaksud Hot Stamping," Astrans.co.id, 2011. Internet: <https://www.astrans.co.id/content/id/berita/15-what-is-hot-stamping>. Nov. 15. 2011 [accessed Okt.10, 2023].
- [5] Hyprowira, "Mengenal Sistem Pneumatik yang Banyak Digunakan untuk Keperluan Industri." Hyprowira.com, 2019. Internet: <https://hyprowira.com/blog/sistem-pneumatik-di-industri>, Sep. 9, 2019 [accessed Ags. 24, 2023].
- [6] Wirawan Sumbodo, Rizki Setiadi, dan Sigit Poedjiono Pneumatik dan Hidrolik. Deepublish, 2017. [Online]. Available: <https://books.google.co.id/books?id=sBIADwAAQBAJ>
- [7] B. Indonesia, "PLC (Programmable Logic Controllers), Cara Kerja dan Fungsi PLC," builder.id, 2021. Internet: <https://www.builder.id/plc-programmable-logic-controllers-cara-kerja-dan-fungsi-plc/> Jun. 16, 2021 [accessed Ags. 28, 2023].
- [8] A. Daniarsyah, "Apa itu PLC? Ketahui Pengertian, Cara Kerja, dan Fungsinya," wira.co.id, 2021. Internet: <https://wira.co.id/plc-adalah/> Nov. 16, 2021 [accessed Ags. 30, 2023].
- [9] B.alldino.as, "Pemrograman Dasar PLC," plc.mipa.ugm.ac.id, 2019. Internet: <https://plc.mipa.ugm.ac.id/pemrograman-dasar-plc/Sep. 24, 2019> [accessed Sep. 1, 2023].
- [10] Misel, "Cara Kerja encoder," misel.co.id, 2021. Internet: <https://misel.co.id/ketahui-cara-kerja-encoder-fungsi-hingga-jenisnya-di-sini/> Dec. 30. 2021 [accessed Sep. 6, 2023].
- [11] Naufal, "Cara Kerja Temperature Controller," Definisi dan cara kerja Temperature Controller, Internet: <https://wma.co.id/articles/temperature-controller/> [accessed Sep. 27, 2023].
- [12] Suprianto, "Teori motor AC dan jenis motor AC," blog.unnes.ac.id, 2015. Internet: <https://blog.unnes.ac.id/antosupri/motor-ac-teori-motor-ac-dan-jenis-motor-ac/> Okt. 12. 2015 [accessed Okt. 14, 2023].